



**RETROAIRE™**

**R10C/H R20C/H R35C/H**

**and R20C with Fedders**

**Unizone Option**

Packaged Terminal Air Conditioner (PTAC)

Packaged Terminal Heat Pump (PTHP)

**Installation, Operation,  
& Maintenance Manual**

ECR International Inc  
2201 Dwyer Avenue  
Utica, NY 13501  
web site: [www.RetroAire.com](http://www.RetroAire.com)



**ECR** international  
EST. 1928  
A Family of Heating & Cooling Brands.

P/N 240010643, Rev. A [10/15/2016]

## TABLE OF CONTENTS

Receiving Information .....	3
Important Safety Information.....	4
Performance Data.....	5
Dimensional/Physical Data.....	6
Product Description.....	8
PTAC/PTHP Installation Preparation.....	12
Installation Instructions — R10C   R10H.....	13
Installation Instructions — R20C  R20H .....	15
Installation Instructions — R20C With Fedders Uni-Zone Option.....	17
Installation Instructions — R35C  R35H.....	19
Sequence Of Operation.....	21
Inspection & Start-Up .....	24
Maintenance .....	30
Troubleshooting.....	32
Hydronic Heat Performance.....	33
Electrical Specifications .....	34

RetroAire™ replacement PTAC/PTHP  
is backed by ECR International and is  
tested and rated in accordance with:  
AHRI Standards 310/380 UL-484



**Information and specifications outlined in this manual in effect at the time of printing of this manual. ECR International reserves the right to discontinue, change specifications or system design at any time without notice and without incurring any obligation, whatsoever.**

## RECEIVING INFORMATION

**Shipping damage MUST be reported to the carrier IMMEDIATELY.  
Examine exterior.  
Remove cover and examine compressor and piping for signs of damage.**

### Inspection

Check shipment against bill of lading.  
Verify equipment received as ordered.

Verify unit:

- Unit size and type correct per submittal sheet and job requirements?
- Voltage correct?
- Hydronic coil included, if required? Piping located as required?
- Factory installed options installed?
- All field installed options included?

Inspect each component for damage. Concealed damage **must** be reported to carrier within 15 days of receipt of shipment.

- Carrier must make proper notation on delivery receipt of all damage identified and complete carrier inspection report.

Purchaser must notify Manufacturer's Service department of all damage and is responsible for filing any necessary claims with carrier.

### General Information

Installation shall be completed by qualified agency. Retain this manual and warranty for future reference.

Installer review this manual to verify unit has been installed correctly. Run unit for one complete cycle to verify proper function.

To obtain technical service or warranty assistance during or after installation, contact your local representative.

Visit our web site [www.retroaire.com](http://www.retroaire.com) for local representative listing.

For further assistance call 1-800-325-5479.

When calling for assistance, please have following information ready:

Model Number \_\_\_\_\_

Serial Number \_\_\_\_\_

Date of installation \_\_\_\_\_

## IMPORTANT SAFETY INFORMATION

All field wiring shall conform to requirements of authority having jurisdiction or in absence of such requirements:

- United States - National Electrical Code, ANSI/NFPA 70
- Canada - CSA C22.1 Canadian Electrical Code Part 1.

### **WARNING**

Fire and electrical shock hazard. Improper installation could result in death or serious injury. Read this manual and understand all requirements before beginning installation.



**Become Familiar With Symbols  
Identifying Potential Hazards.**

### **DANGER**

Indicates a hazardous situation which, if not avoided, WILL result in death or serious injury.

### **WARNING**

Indicates a hazardous situation which, if not avoided, could result in death or serious injury.

### **CAUTION**

Indicates a hazardous situation which, if not avoided, could result in minor or moderate injury.

### **NOTICE**

Indicates information which should be followed to ensure proper installation and operation.

## Safety Information

- Installation by qualified personnel.
- Turn off electrical supply before servicing unit.
- Inspect all parts for damage prior to installation and start-up.
- Do not use unit if it has damaged wiring, is **not working** properly, or has been damaged or dropped.
- Connect to properly grounded electrical supply with proper voltage as stated on rating plate.
- Have proper over current protection (i.e. time- delay fuse/HACR Breaker) as listed on Rating Plate.
- Connect unit to properly grounded electrical supply. Do not fail to properly ground this unit.
- Tampering voids all warranties.

### **WARNING**

Tampering with PTAC/PTHP is dangerous and could result in serious injury or death. Do not modify or change this unit.

## PERFORMANCE DATA

**Table 1 Performance Data - Cooling**

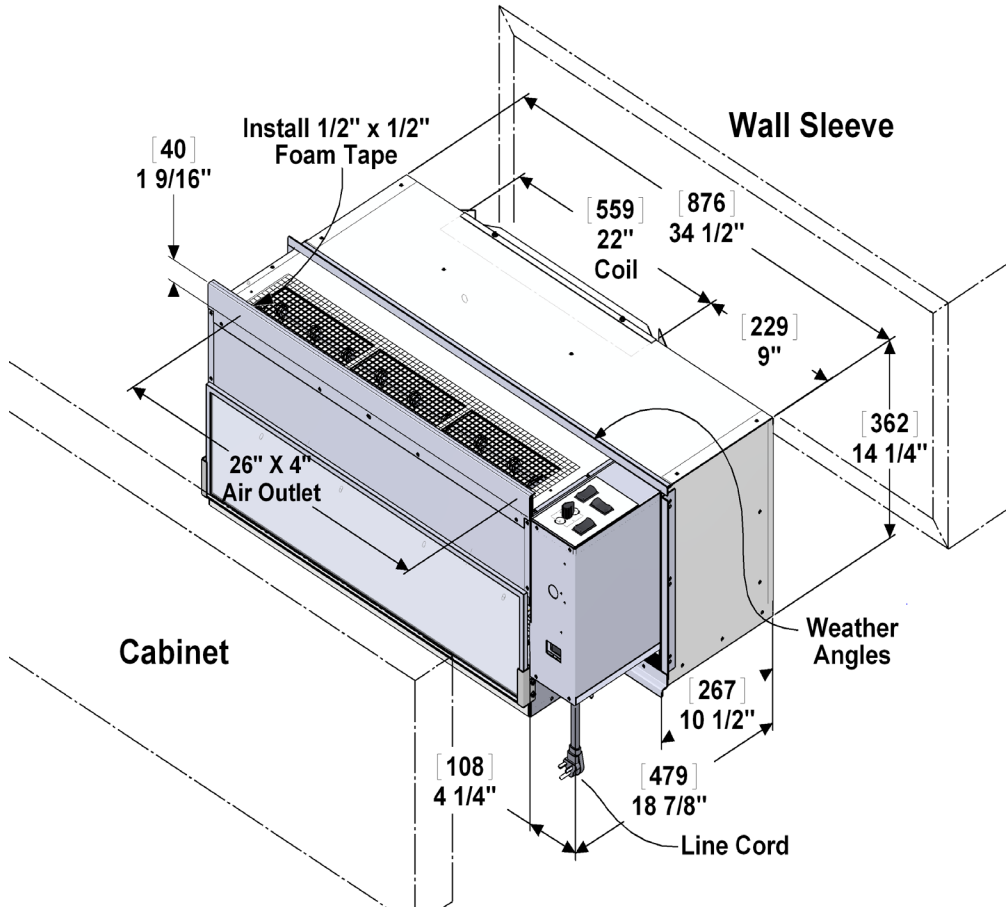
Models R10C   R20C R35C	Voltage		Cooling Capacity	EER	Sensible Heat Ratio	Indoor Air Flow	Fresh Air Inlet Flow	Outdoor Sound Level	Shipping Weight
			Btuh (kW)			CFM (L/S)	CFM (L/s)	dBa	lbs (Kg)
R_ _C 09	A	115	9000 (2.7)	9.0	0.79	440 (207.7)	35 (17)	75	140 (63.5)
	D	208/230				350 (165.2)			
	E	267/277	9400 (2.8)	8.9		440 (207.7)			
R_ _C 12	D	208/230	11600 (3.4)	8.4	0.66	350 (165.2)	50 (24)	69	140 (63.5)
	E	267/277	11700 (3.4)			440 (207.7)			
R_ _C 15	D	208/230	14400 (4.2)	7.8	0.69	400 (188.8)	60 (28)	70	140 (63.5)
	E	267/277				450 (212.4)			
R_ _C 18	D	208/230	15600 (4.6)	7.7	0.67	380 (179.3)	95 (45)	69	140 (63.5)

**Table 2 Performance Data - Heating**

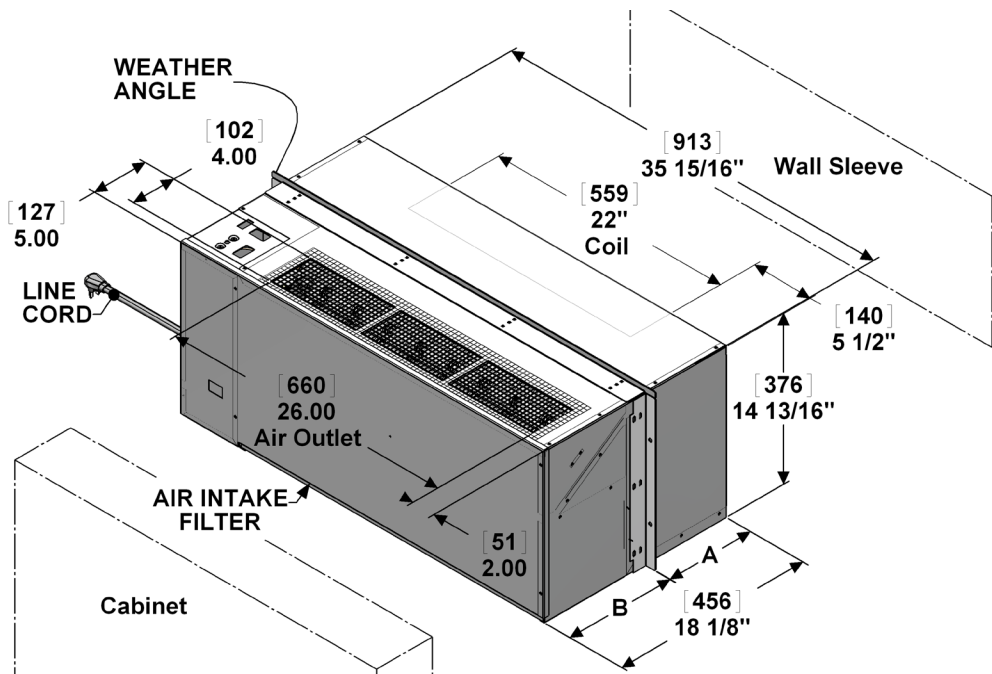
Models R10H R20H R35H	Voltage		Cooling Capacity	EER	Indoor Air Flow Cooling	Heating Capacity	COP	Indoor Air Flow Heating	Sensible Heat Ratio	Fresh Air Flow	Outdoor Sound Level	Shipping Weight
			Btuh (kW)		CFM (L/S)	Btuh (kW)		CFM (L/S)		CFM (L/S)	dBa	lbs (Kg)
R_ _H 09	D	208/230	9000 (2.7)	8.9	350 (165.2)	8500 (2.5)	2.7	400 (189)	0.79	35 (17)	75	140 (63.5)
	E	267/277	9400 (2.8)	8.8	440 (207.7)	9100 (2.7)		450 (212)				
R_ _H 12	D	208/230	11400 (3.3)	8.4	350 (165.2)	11200 (3.3)	2.6	400 (189)	0.66	50 (24)	69	
	E	267/277			400 (188.8)			450 (212)				
R_ _H 15	D	208/230	14400 (4.2)	7.7	400 (188.8)	14800 (4.3)	2.5	450 (212)	0.69	60 (28)	7070	
	E	267/277	14000 (4.1)	7.8	450 (212.4)			500 (236)				

**DIMENSIONAL/PHYSICAL DATA**

**Figure 1 R10C | R10H Dimensions - Inches (mm)**

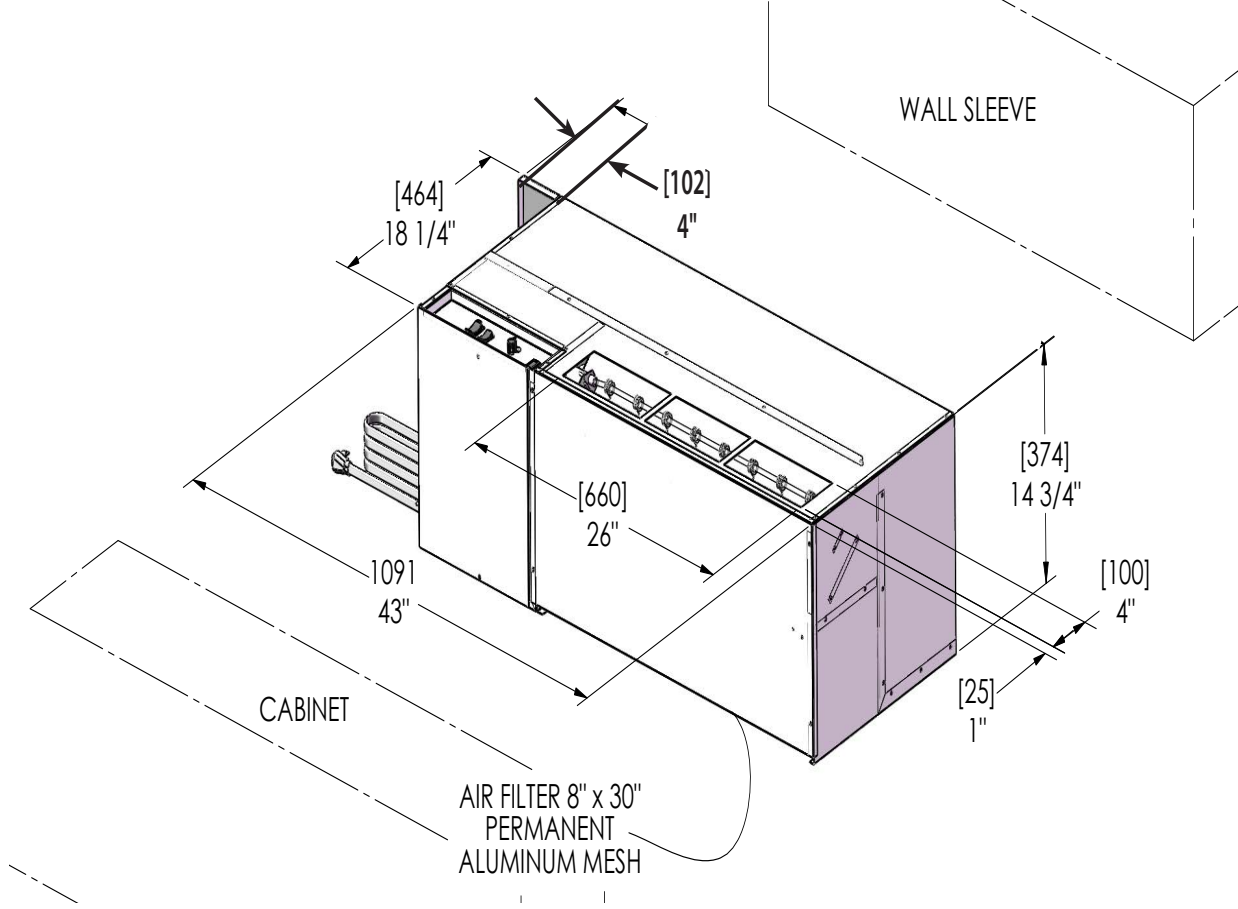


**Figure 2 R20C | R20H Dimensions - Inches (mm)**

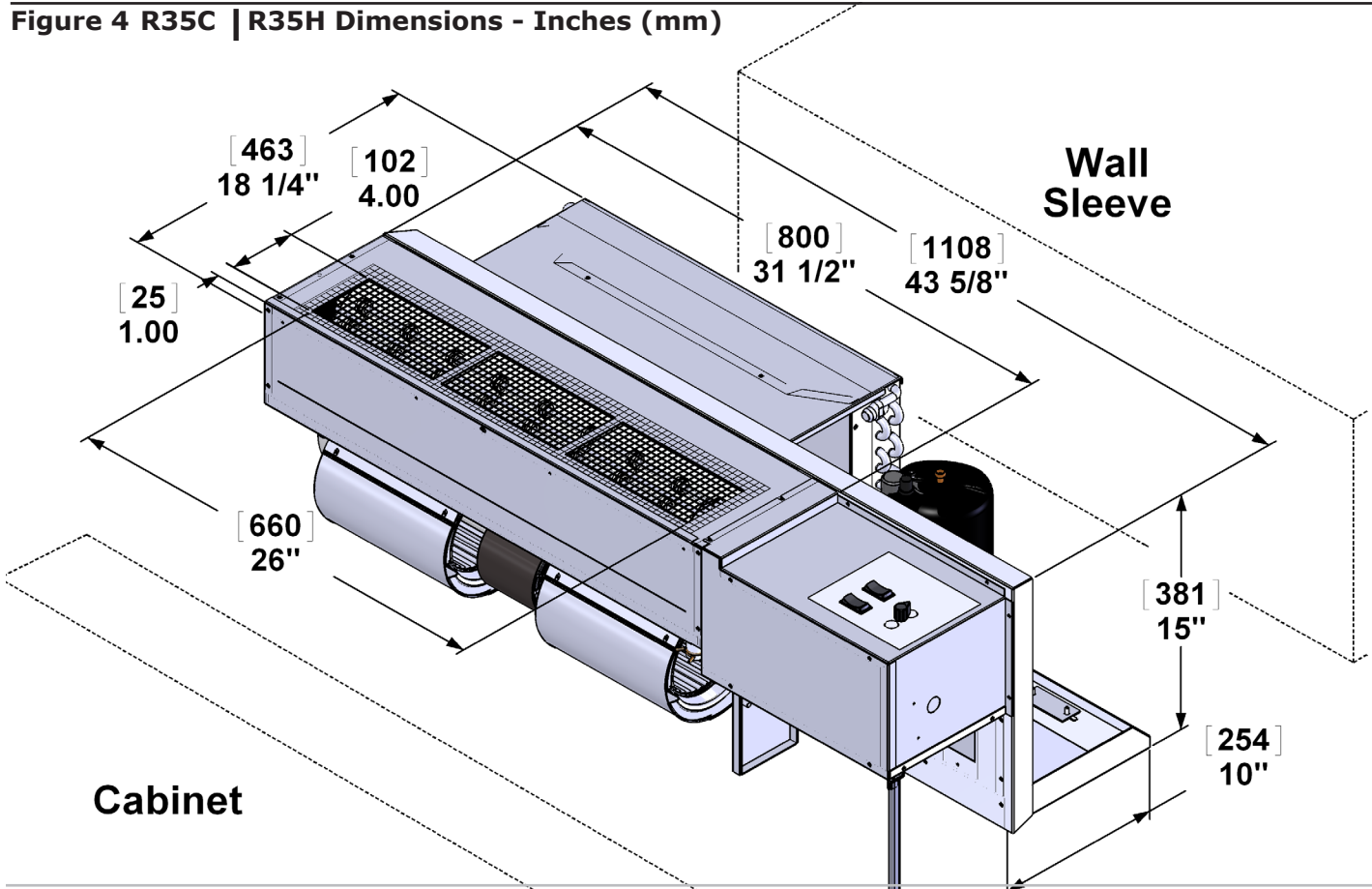


**DIMENSIONAL/PHYSICAL DATA**

**Figure 3 R20C With Fedders Unizone Option - Dimensions - Inches (mm)**

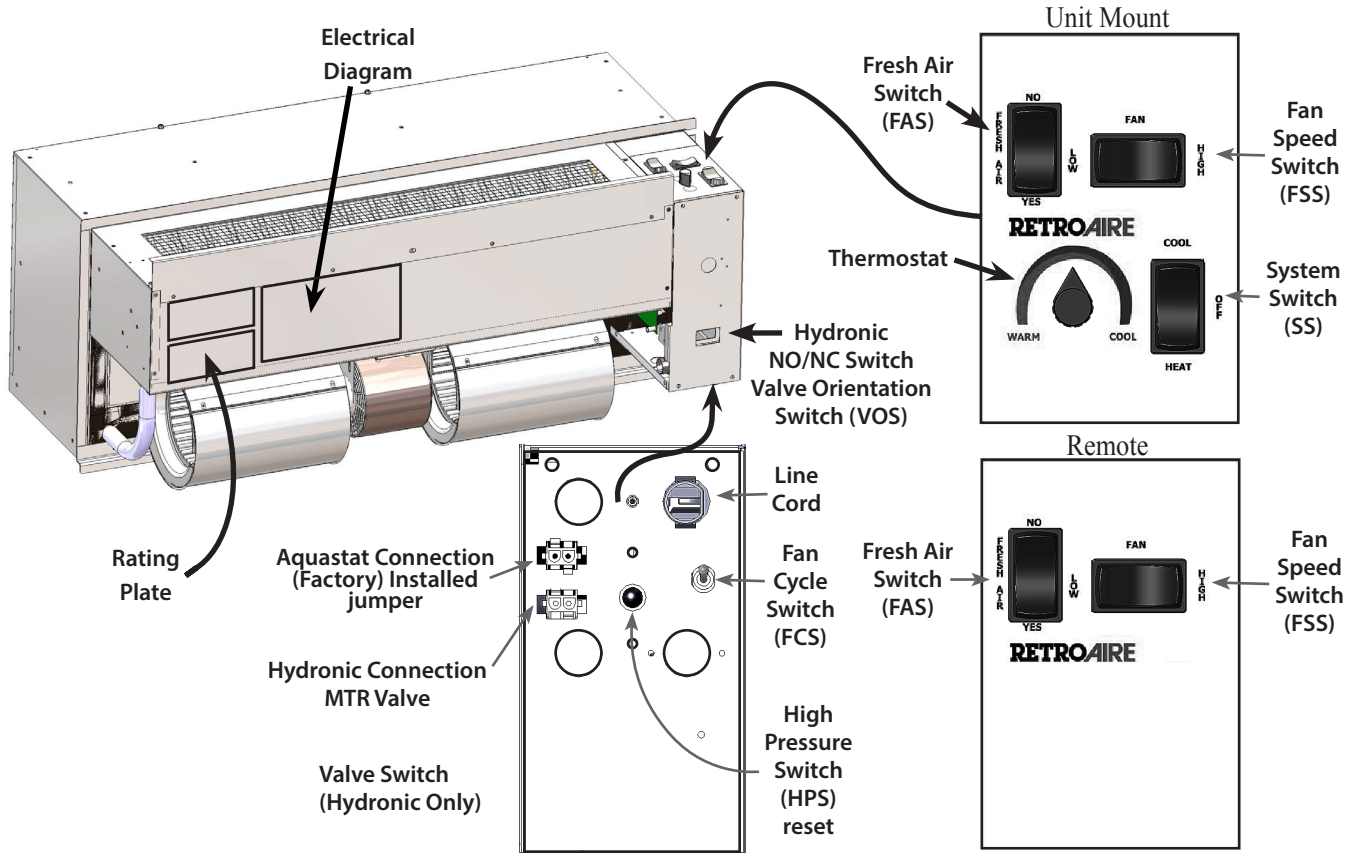


**Figure 4 R35C | R35H Dimensions - Inches (mm)**

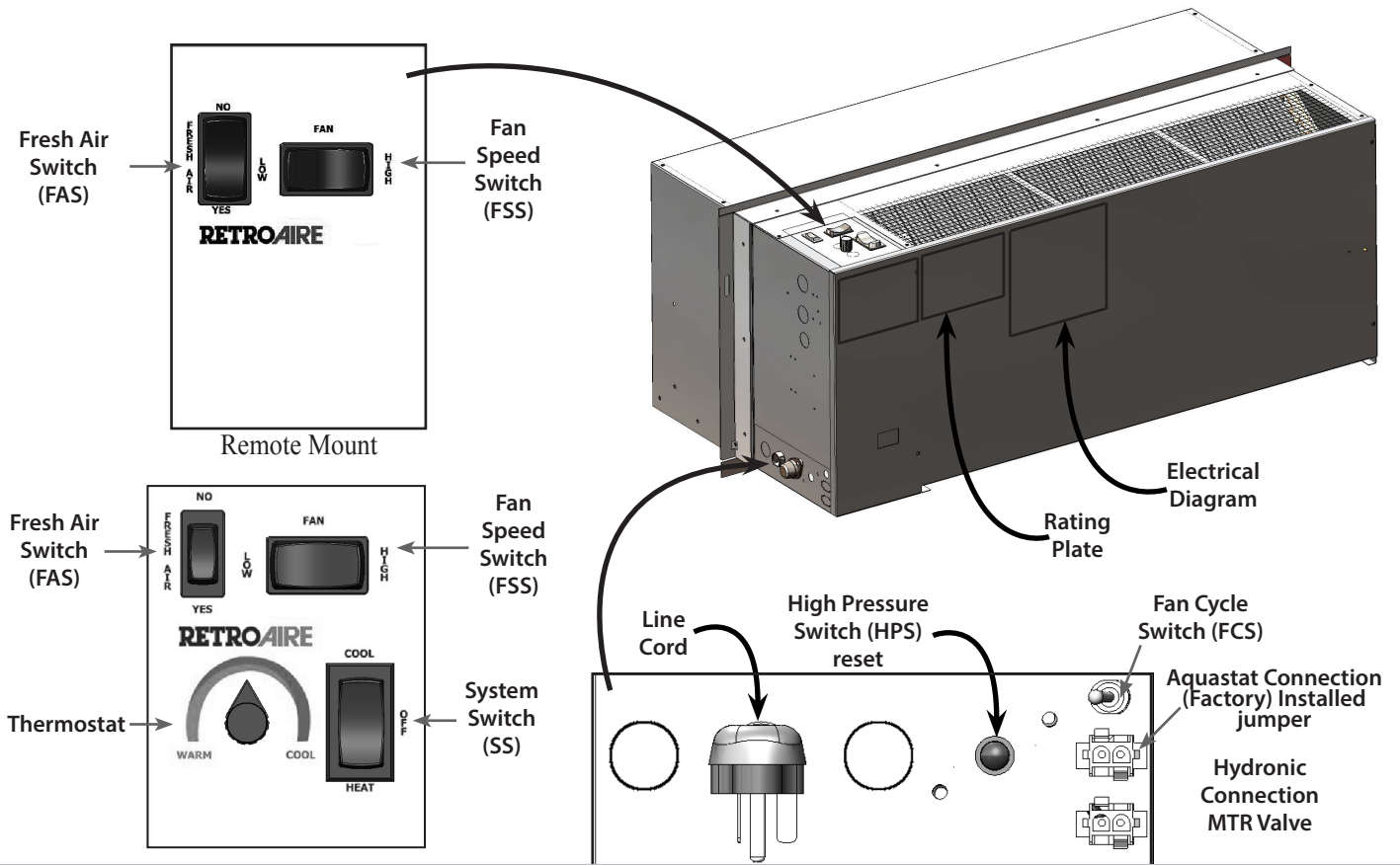


# PRODUCT DESCRIPTION

**Figure 5 R10C | R10H Chassis**

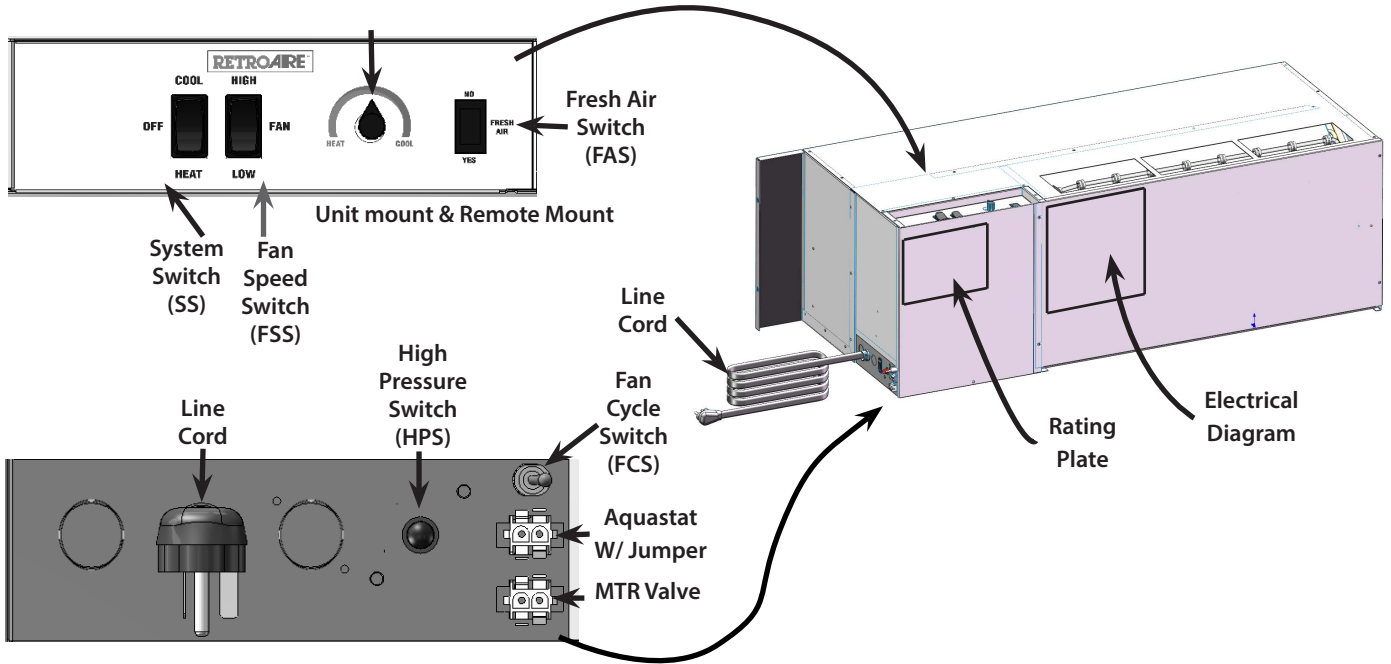


**Figure 6 R20C | R20H Chassis**

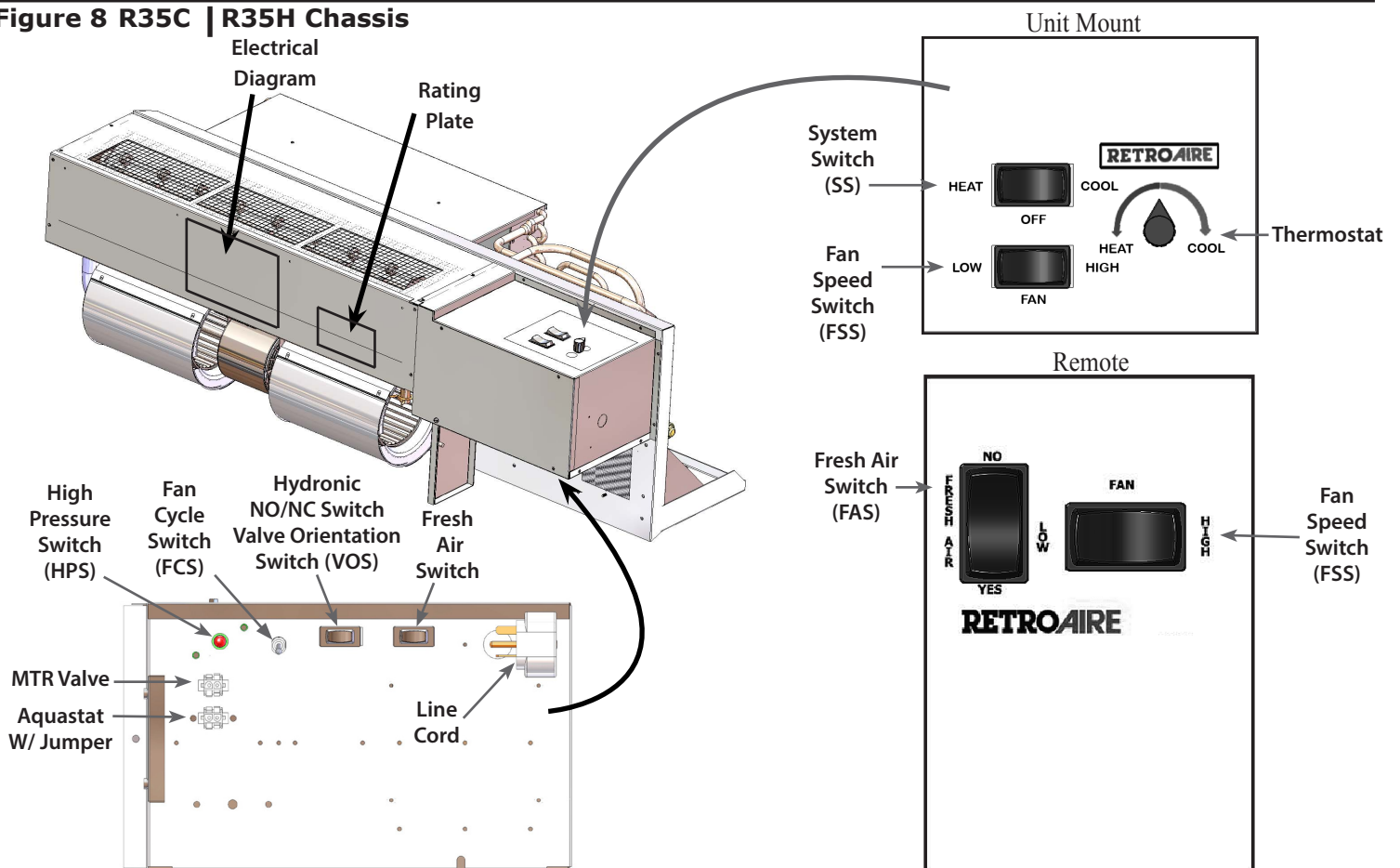


# PRODUCT DESCRIPTION

**Figure 7 R20C With Fedders Uni-Zone Option**



**Figure 8 R35C | R35H Chassis**



## PRODUCT DESCRIPTION

### Product Description

- RetroAire Replacement Packaged Terminal Air Condition/Heat Pumps units are straight cooling (PTAC) or heat pump systems (PTHP).
- Both PTAC and PTHP configurations fit wall sleeves of units listed on front cover.
- Heat pumps (PHTP) operate in mechanical heat mode down to outdoor temperature of 35°F (1.7°C). Below 35°F (1.7°C) heating is accomplished by auxiliary heat option.

### Retroaire PTAC/PHTP

- R-410A refrigerant.
- High-efficiency rotary compressors.
- Two fan speeds.
- Positive condensate re-evaporation.
- PTAC/PHTP units are available in nominal sizes of 9,000 Btuh, (2.6kW) 12,000 Btuh (3.5kW) or 15,000 Btuh (4.4kW).
- PTAC units (straight cooling only) are available at 18,000 Btuh (5.3kW).
- Coefficient of performance (COP) ratings 2.90 for heat pumps.

### Standard Controls And Components

#### Construction

- Chassis constructed of 20 gauge galvanized steel.
- Condenser baffle options accommodate extended wall sleeve applications. (Consult manufacturer).
- Powder-coated condenser and evaporator drain pan.
- Foam strip seal for supply air duct.
- Weather strip insulation.

#### Air Systems

- Thermally-protected motor PSC type.
- Indoor fan forward curved type, directly mounted to motor shaft.
- Unit mount controls include field selection switch to control indoor fan by either cycling with compressor operation or continuously with unit.

#### Condensate Removal

- Outdoor fan incorporates condensate slinger ring. Condensate is thrown onto coil, where it evaporates.
- Thermostatic drain pan valve for condensate elimination when outdoor temperature drops below 60°F (15°C) (heat pump units only).

#### Controls

- Unit-mounted operating controls include thermostat, fan speed control, heat/cool switch, fan cycle switch, fresh air

switch (if equipped).

- Use of 1-stage or 2-stage thermostat. 2 stage thermostat is capable of activating emergency heat if auxiliary heat source is available.
- Low ambient protection — see "Microprocessor control board" for details.
- Ability to control a normally-open or normally-closed motor valve switch (on hydronic heat units only). Valve controls must be ordered for 24V or line voltage.
- All hydronic heat units include molex plugs for connection of hydronic valve motor.
- Remote mount controls include fan speed control and fresh air switch (if equipped).
- Equipped with manual reset high pressure switch which prevents abnormal high pressure operation.

#### Microprocessor Control Board

- Universal control board used in straight cooling, electric resistance heat, hydronic heat, or cooling/heat pump applications.
- Random start timer prevents multiple units from simultaneous startups after power interruption or on initial power-up.
- Fan purge — fan remains on for 60 seconds after heat/cool is satisfied.
- Anti-short-cycle compressor protection prevents compressor from rapid cycling.
- Freeze-protection prevents evaporator coil freeze up.
- Low ambient lockout prevents compressor operation in outdoor temperatures less than 35°F (1.7°C). (On PHTP units supplied with unit-mounted control, control causes automatic changeover to auxiliary heat, if installed.)
- Test operation — all timers are temporarily suppressed to allow ease of testing or troubleshooting.
- Control board LED provides self-diagnostic troubleshooting codes, see "Sequence of operation."

## PRODUCT DESCRIPTION

### Manufacturer Installed Options (Consult manufacturer)

- 208/230V (all)
- 265/277V(12 and 15 only)
- 115V (09 Model Only)
- Corrosion-resistant coil option — used for seacoast and harsh-environment usage; coated aluminum fin/copper tube condenser coil.
- Motorized fresh-air damper
- Supplemental electric heat
- Hydronic heat controls
- Front air intake

### Field-Installed Accessories

- Hydronic heat — coil assembly is shipped loose for field installation.
- Remote wall thermostat — digital 1-stage or 2-stage available.
- Wall sleeves, louvers, and cabinets.
- Control - delays fan start-up until coil reaches 100°F (38°C) to virtually eliminate "cold" blow condition.
- Hydronic control valve , water 2 way & 3 way.
- Hydronic control valve, steam 2 way.
- Hydronic Isolation valve, 1/2 in sweat connection.

## PTAC/PTHP INSTALLATION PREPARATION

### **WARNING**

Electrical shock hazard. Turn OFF electrical power supply at service panel before making electrical connections. Failure to do so could result in death or serious injury.

### **WARNING**

Moving parts if not avoided, could result in death or serious injury. Avoid contact with moving parts when testing or servicing unit.

### Electrical Supply

- All field wiring shall conform to requirements of authority having jurisdiction or in absence of such requirements:
  - United States - National Electrical Code, ANSI/NFPA 70
  - Canada - CSA C22.1 Canadian Electrical Code Part 1.

### **Note**

- Before opening existing unit, open power supply disconnect switch. Secure switch in open position during installation. Attach sign stating "DO NOT TURN ON".
- Unplug existing unit at wall outlet on plug and receptacle connection units. DO NOT plug new unit until installation is complete and start-up checklist is completed.
- **UNITS RATED 208/230V** — RetroAire unit is wired for 230V primary voltage from manufacture. Transformer must be rewired by installer if jobsite voltage is 208V. Change transformer tap from orange to red. See wiring diagram for details.
- Protect with separate branch circuit protected by fuse or breaker. Refer to unit rating plate for proper wire and breaker or fuse size.
- Use of extension cords is prohibited.
- DO NOT connect RetroAire unit to circuit with incorrectly-sized over current protection device.
- All cord-connected 265 volt units must be plugged into receptacles within unit subbase or chassis.

### Verify existing wall sleeve/enclosure:

- Use RetroAire replacement PTAC/PTHP's with metal wall sleeves.
- Secure existing front panels by screws that prevent contact with all parts.
- Minor dimensions of openings must not exceed ½ inch (12.5mm).
- Dimensions of indoor air discharge grill shall be not less than 26" x 4". Grill shall separate top surface of chassis from top surface of discharge grill by minimum of 1 in (25.4mm).
- For all models, outdoor openings must prevent contact of all moving parts by means of louvers or grills, with minor dimension not exceeding 1 in (25.4mm).

### Electrical Power Connection

1. Verify RetroAire unit rating plate for circuit ampacity and required breaker or fuse size.
2. Verify existing breaker or fuse is correct size.
  - Replace breaker or fuse if incorrectly-sized.
  - Breakers shall be type HACR only.
3. Cord-connected units — verify wall outlet is correct rating. Outlet's blade configuration must match cord supplied with RetroAire unit.
4. Hard-wired units — verify power wiring is correctly sized. Inspect existing wiring for cuts or frayed wires. Replace any damaged wiring.

### Remove Old Chassis

1. Disconnect power or unplug cord before proceeding.
2. Remove front of existing room enclosure to expose old chassis.
3. Loosen tie-down bolts or screws and remove old chassis.
4. Dispose of old chassis following existing State and/or Federal regulations.
5. Inspect wall sleeve/cabinet for rust, holes, or damage.
  - A. Clean wall sleeve of any dirt.
  - B. Repair any damage.
  - C. Verify proper drainage of condensate or rain water to exterior of building.
6. Remove or repair old weather seals. Make note of location for installation of new seals.
7. Check wall sleeve/cabinet to ensure all drain holes are open and:
  - A. Wall sleeve/enclosure is level left to right
  - B. Back is pitched to outside by ½ in (12.5mm) maximum.
8. Inspect outdoor louver for minimum free area of 70%. Remove any obstructions before installing new chassis.
9. Read and understand all instructions in this manual before attempting installation or operation.

## Installation - R10C | R10H

1. **Verify existing wall thickness** — distance from condenser coil to outdoor louver varies with sleeve depth.
  - Unit(s) ship standard with 1-3/8" (35mm) & 1-1/8" (38mm) baffles. Figure 8.
  - Optional condenser-side air baffle kit for chassis installation in deeper-than-standard wall sleeves is available.
2. **Verify weather angles** — Slide unit into wall sleeve.
  - If supply duct on cooling chassis does not line up with supply vent on room cabinet, adjust or change factory installed weather angle on top and sides. Allow for adjustment to align supply vent when mounting unit to wall sleeve Figure 9.
  - Slide unit back in wall sleeve to verify proper fit after adjustment.
3. **Install baffles** — Slide unit back out of wall sleeve. Remove both supplied sets of baffles from kit bag. Install only one set of left and right side baffles on condenser coil by completing following steps:
  - A. Verify baffles come in contact with outdoor louver.
  - B. Verify baffles are directed inward toward center of coil Figure 11.
  - C. Secure baffles tightly into existing holes of condenser coil using screws provided.

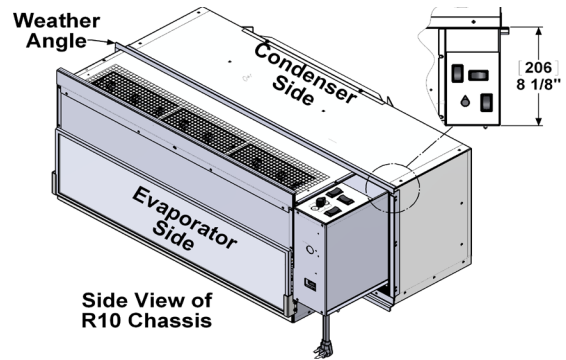
**Note** Install correct condenser air baffles or performance may be impaired.

4. **Apply 2" x 1-1/2" open-cell foam strips** around supply air duct to ensure all conditioned air is delivered into room Figure 11. Failure to do so results in recirculation of conditioned air through cabinet causing unit to short cycle and coil to freeze.
5. **Apply 1" x 1" open-cell foam strips** to weather angle. Prevents outside air from entering around chassis to room from sides and top of cabinet.

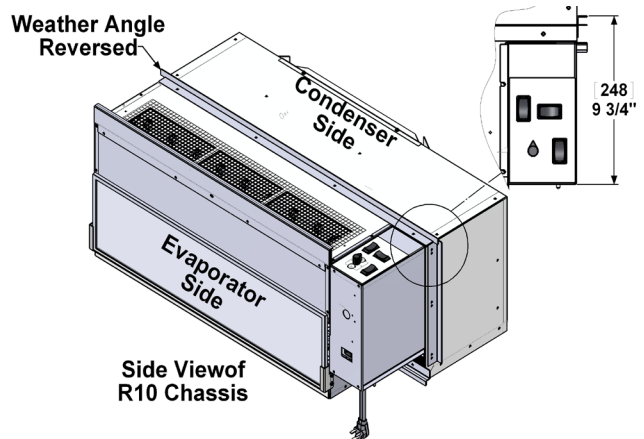
Install strips between wall sleeve and cooling chassis Figure 13. Verify solid air seal between wall sleeve and chassis. Air leakage from outdoor to indoor will result in system problems (example — coils freezing, short cycling, and constant running of unit).

6. **Connecting (optional) hydronic coil controls** — If hydronic heat option has been ordered, field install hydronic coils on new unit.
  - A. Hydronic coils are not factory installed.
  - B. Old unit coil can be located in subbase, under or above chassis in special attachment. It is necessary to know where coil is to be located and physical size of coil if ordered for replacement. Install new coil in same manner as coil it is replacing.
    - Remove 2-position connector assembly from kit bag supplied with unit (2 yellow wires attached).
    - Connect 2-position connector to 2-position connection located on bottom of control box panel.

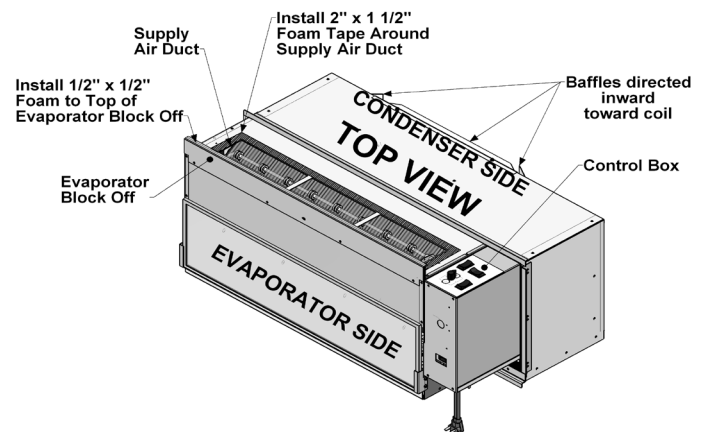
**Figure 9 Weather Angles (in factory location)**



**Figure 10 Weather Angles Reversed to Gain Extra Depth**



**Figure 11 Direction of Baffles and Foam Installation**



## 7. Field install (optional) Aquastat

- A. Remove black jumper wire located on bottom panel of control box (*also terminated with 2-position connector*).
- B. Cut jumper wire in middle and splice Aquastat to jumper.
- C. Place connector back into original location. Refer to wiring diagram on unit for details.

## 8. Secure chassis

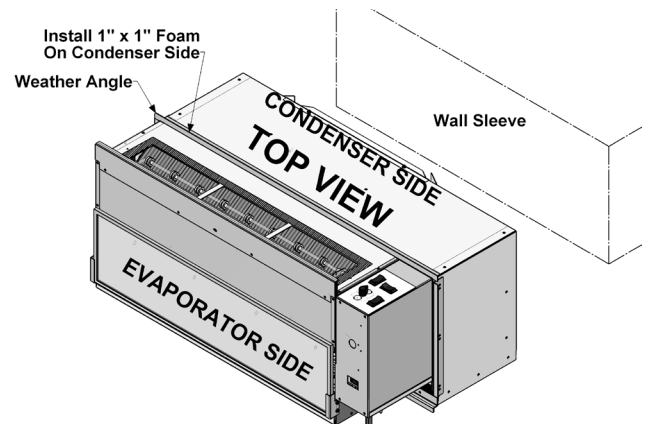
- Verify all seals are properly located,
- Verify correct baffles are attached to condenser coil, and properly orientated,
- Slide unit into final position and tighten tie down bolts or screws.

## 9. Hard-wired units – If unit is hard wired, verify existing wiring and over current protection.

- A. Remove line cord wires from PTAC/PTHP power entrance terminals.
- B. Route power supply wiring through strain-relief bushing and connect leads to power entrance terminals.
- C. Secure strain-relief clamp. (If wiring is through conduit, insert conduit through control box knockout and secure in place.)
- D. **DO NOT** turn on power until completing instructions in "Inspection and Startup" on page 24.

## 10. Do not plug in line cord, Follow instructions in "Inspection and Startup".

**Figure 12 Foam tape Installation Against Wall Sleeves**



## Installation - R20C | R20H

1. **Verify existing wall thickness** — distance from condenser coil to outdoor louver varies with sleeve depth.
  - Standard air baffles are included with each unit to accommodate most installation requirements.
  - Other air baffle kits are available from manufacturer (for unique applications).
2. **Verify Weather Angle** — Slide unit into wall sleeve.
  - If supply duct on cooling chassis does not line up with supply vent on room cabinet, it may be necessary to reverse the manufacturer installed weather angles on top and sides.
  - This will allow approximately 1" of adjustment for alignment with supply vent when mounting unit to wall sleeve. See Figures 13 and 14. Slide the unit back in the wall sleeve to verify proper fit.

Adjustable Weather Angle				
Dimension "A"	8 5/8"	7 7/8"	9 11/16" (1)	8" (2)
Dimension "B"	9 1/2"	10 1/4"	8 7/16" (1)	10 1/8" (2)
Dimensions are calculated without foam gaskets. (1) Standard position — Factory installed. (2) Position for Climate Master 702 and 703.				

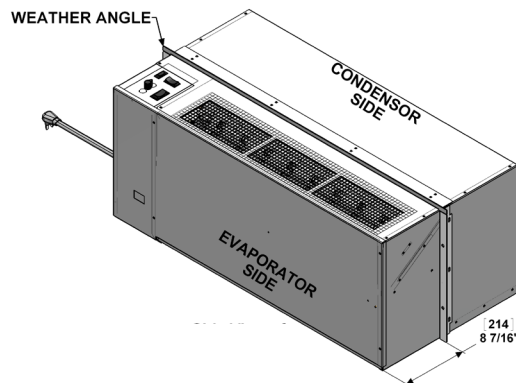
3. **Install baffles** — Slide unit back out of wall sleeve. Remove both supplied sets of baffles from kit bag. Install only one set of left and right side baffles on condenser coil as follows:
  - A. Verify baffles come in contact with outdoor louver.
  - B. Verify baffles are directed inward toward center of coil. Figure 15.
  - C. Secure baffles into existing holes of condenser coil using screws provided.

**Note** Install correct condenser air baffles or performance may be impaired.

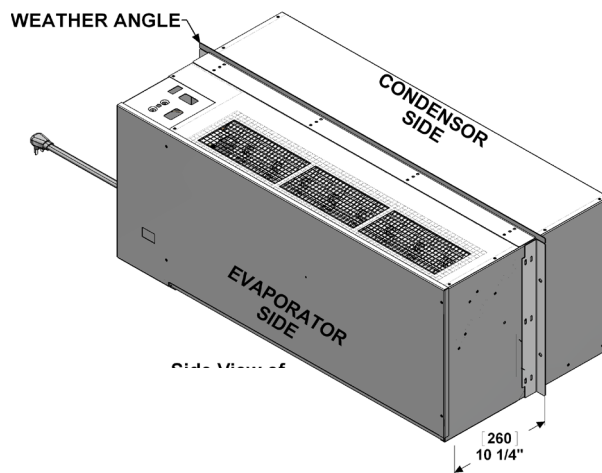
4. **Apply 1/2" x 1/2" open-cell foam strips** around supply air duct to ensure all conditioned air is delivered into room Figure 15. Failure to do so results in recirculation of conditioned air through cabinet causing unit to short cycle and coil to freeze.
5. **Apply 1" x 1" open-cell foam strips** to weather angle. Prevents outside air from entering around chassis to room from sides and top of cabinet.
 

Install strips between wall sleeve and cooling chassis Figure 16. Verify solid air seal between wall sleeve and chassis. Air leakage from outdoor to indoor will result in system problems (example — coils freezing, short cycling, and constant running of unit).

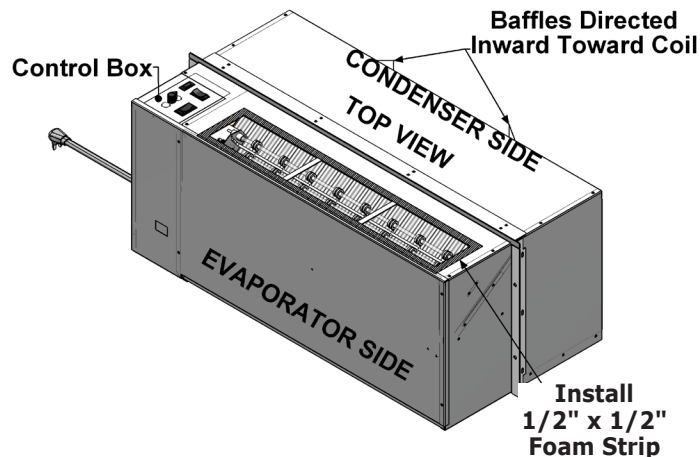
**Figure 13 Weather Angle - Factory Location**



**Figure 14 Weather Angles Reversed to Gain Extra Depth**



**Figure 15 Direction of Baffles and Foam Installation**



**6. Connect (optional) hydronic coil controls** — If hydronic heat option has been ordered, hydronic coils will need to be field installed on new unit.

- A. Hydronic coils are not factory installed and need to be ordered and field installed on new unit.
- B. Coil with old unit can be located in subbase, under or above chassis in special attachment. It is necessary to know where coil is to be located and physical size of coil if ordered for replacement. New coil should be installed in same manner as coil it is replacing.
  - Remove 2-position connector assembly from kit bag supplied with unit (2 yellow wires attached).
  - Connect 2-position connector to 2-position connection located on bottom of control box panel.

**7. Field install (optional) Aquastat**

- A. Remove black jumper wire located on bottom panel of control box (*also terminated with 2-position connector*).
- B. Cut jumper wire in middle and splice Aquastat to jumper.
- C. Place connector back into original location. Refer to wiring diagram on unit for details.

**8. Secure chassis**

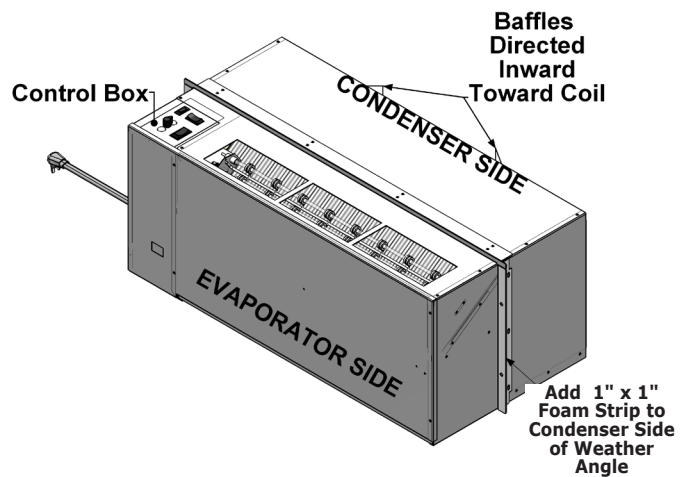
- Verify all seals are properly located,
- correct baffles are attached to condenser coil, and properly orientated,
- slide unit into final position and tighten tie down bolts or screws as necessary.

**9. Hard-wired units** — If unit is hard wired, verify existing wiring and over current protection.

- A. Remove line cord wires from PTAC/PTHP power entrance terminals.
- B. Route power supply wiring through strain-relief bushing and connect leads to power entrance terminals.
- C. Secure strain-relief clamp. (If wiring is through conduit, insert conduit through control box knockout and secure in place.)
- D. **DO NOT** turn on power until completing instructions in "Inspection and Startup" on page 24.

**10. Do not plug in line cord**, Follow instructions in "Inspection and Startup".

**Figure 16** Foam tape installation against wall sleeve



## INSTALLATION INSTRUCTIONS — R20C WITH FEDDERS UNI-ZONE OPTION

### Installation - R20C w/Fedders Uni-Zone Option

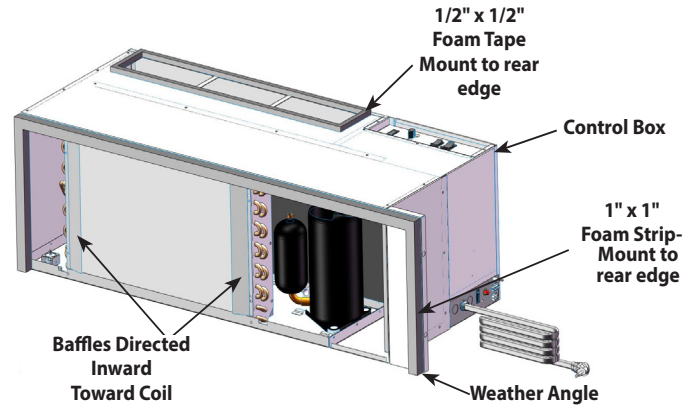
- 1. Verify existing wall thickness** — distance from condenser coil to outdoor louver varies with sleeve depth.
  - Standard air baffles are included with each unit to accommodate most installation requirements.
  - Optional condenser side baffle kit is available from manufacturer for installation in deeper than standard walls.
  - Weather angles should need no adjustment.
- 2. Verify air supply alignment** — Slide unit into wall sleeve.
  - Supply duct on cooling chassis should line up with supply vent on room cabinet.
- 3. Install baffles** — Slide unit back out of wall sleeve. Remove supplied baffles from kit bag. Install left and right side baffles on condenser coil as follows:
  - A. Verify baffles come in contact with outdoor louver.
  - B. Verify baffles are directed inward toward center of coil Figure 17.
  - C. Secure baffles into existing holes of condenser coil using screws provided.

**Note** Install correct condenser air baffles or performance may be impaired.

- 4.** Install weather angle supplied on side of unit. Secure with provided screws. Face insulation toward interior of building.
- 5. Apply 1/2" x 1/2" open-cell foam strips** around supply air duct to ensure all conditioned air is delivered into room Figure 17. Failure to do so results in recirculation of conditioned air through cabinet causing unit to short cycle and coil to freeze.
- 6. Apply 1" x 1" open-cell foam strips** to weather angle. Prevents outside air from entering around chassis to room from sides and top of cabinet.

Install strips between wall sleeve and cooling chassis Figure 17. Verify solid air seal between wall sleeve and chassis. Air leakage from outdoor to indoor will result in system problems (example — coils freezing, short cycling, and constant running of unit).
- 7. Connect (optional) hydronic coil controls** — If hydronic heat option has been ordered, hydronic coils will need to be field installed on new unit.
  - A. Hydronic coils are not factory installed and need to be ordered and field installed on new unit.
  - B. Coil with old unit can be located in subbase, under or above chassis in special attachment. It is necessary to know where coil is to be located and physical size of coil if ordered for replacement. Install new coil in same manner as coil it is replacing.
    - Remove 2-position connector assembly from kit bag supplied with unit (2 yellow wires attached).
    - Connect 2-position connector to 2-position connection located on bottom of control box panel.

**Figure 17** Baffle Direction and Foam Installation



### 8. Field install (optional) Aquastat

- A. Remove black jumper wire located on bottom panel of control box (*also terminated with 2-position connector*).
- B. Cut jumper wire in middle and splice Aquastat to jumper.
- C. Place connector back into original location. Refer to wiring diagram on unit for details.

### 9. Secure chassis

- Verify all seals are properly located.
- Verify correct baffles are attached to condenser coil, and properly orientated.
- Slide unit into final position and tighten tie down bolts or screws.

### 10. Hard-wired units — If unit is hard wired, verify existing wiring and over current protection.

- A. Remove line cord wires from PTAC/PTHP power entrance terminals.
- B. Route power supply wiring through strain-relief bushing and connect leads to power entrance terminals.
- C. Secure strain-relief clamp. (If wiring is through conduit, insert conduit through control box knockout and secure in place.)
- D. **DO NOT** turn on power until completing instructions in "Inspection and Startup" on page 24.

### 11. Do not plug in line cord, Follow instructions in "Inspection and Startup".

## Installation - R35C

1. **Verify existing wall thickness** — distance from condenser coil to outdoor louver varies with sleeve depth.
  - Chassis includes ½" air baffle to accommodate the most common condenser coil to outdoor louver requirements.
  - Optional condenser-side air baffle kit for chassis installation in deeper than standard walls is available from manufacturer.
2. **Verify air supply alignment** — slide unit into wall-sleeve. Supply duct on the cooling chassis should line up with supply vent on room cabinet.
3. **Install baffles** — Slide unit back out of wall sleeve. Remove supplied baffles from kit bag. Install only one set of left and right side baffles on condenser coil by completing following steps:
  - A. Verify baffles come in contact with outdoor louver.
  - B. Verify baffles are directed inward toward center of coil *Figure 18*.
  - C. Secure baffles tightly into existing holes of condenser coil using screws provided.

**Note** Install correct condenser air baffles or performance may be impaired.

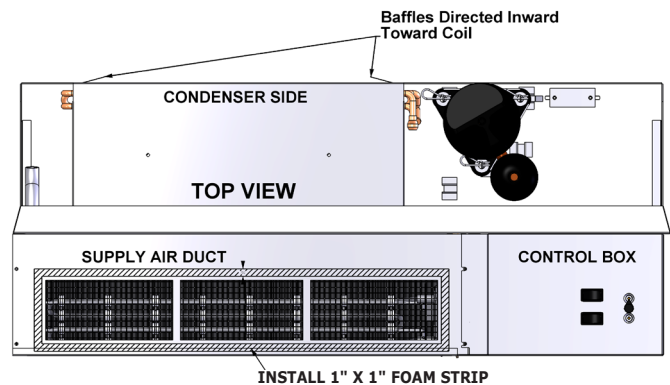
4. **Apply 1" x 1" open-cell foam strips** to weather angle. Prevents outside air from entering around chassis to room from sides and top of cabinet.

Install strips between wall sleeve and cooling chassis. See *Figure 18*. Verify solid air seal between wall sleeve and chassis. Air leakage from outdoor to indoor will result in system problems (example — coils freezing, short cycling, and constant running of unit).

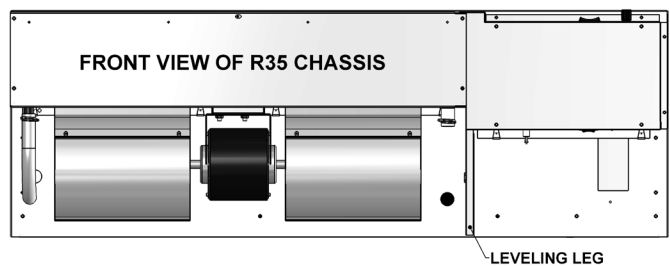
R35C/H is equipped with a bracket allowing unit to be adjusted up and down in the chassis of un-leveled wall sleeves. Adjust leveler leg to desired height and tighten down using bolts supplied on bracket. See *Figure 19*.

5. **Connecting (optional) hydronic coil controls** — If hydronic heat option has been ordered, hydronic coils will need to be field installed on new unit.
  - A. Hydronic coils are not factory installed and need to be ordered.
  - B. Coil with old unit can be located in subbase, under chassis in special attachment. It is necessary to know where coil is to be located and physical size of coil if ordered for replacement. New coil should be installed in same manner as coil it is replacing.
  - C. Remove 2-position connector assembly from kit bag supplied with unit (2 yellow wires attached).
  - D. Connect 2-position connector to 2-position connection located on bottom of control box panel.

**Figure 18** Direction Of Baffles and Foam Installation



**Figure 19** Front View of Chassis



### 6. Field install (optional) Aquastat

- A. Remove black jumper wire located on bottom panel of control box (also terminated with 2-position connector).
- B. Cut jumper wire in middle and splice control to jumper.
- C. Place connector back into original location. Refer to wiring diagram on unit for details.

### 7. Secure chassis

- Verify all seals are properly located.
- Verify correct baffles are attached to condenser coil, and properly orientated.
- Slide unit into final position and tighten tie down bolts or screws.

### 8. Hard-wired units — If unit is hard wired, verify existing wiring and over current protection.

- A. Remove line cord wires from PTAC/PTHP power entrance terminals.
- B. Route power supply wiring through strain-relief bushing and connect leads to power entrance terminals.
- C. Secure strain-relief clamp. (If wiring is through conduit, insert conduit through control box knockout and secure in place.)
- D. DO NOT turn on power until completing instructions in "Inspection and Startup" on page 24.

### 9. Do not plug in line cord, Follow instructions in "Inspection and Startup".

## SEQUENCE OF OPERATION

### General

**R\_\_C** units are straight cool, single stage air conditioners available with electric or hydronic heat.

**R\_\_H** units are limited range, single stage heat pump. Mechanical compression heating (heat pump mode) is locked out at outdoor temperatures of approximately 35°F (1.7°C) and below. Below these ambient temperatures, auxiliary electric or hydronic heat will be used.

**Microprocessor Control Board** Thermostat and control connections are made to control board.

**A. Two configuration jumpers are located on board, see Figure 20. Heat Pump Configuration Jumper is 3 pin jumper.**

- Straight **Cool** units R\_\_C, the jumper should be located on the outside two pins.
  - **Heat** Pump units R\_\_H, the jumper should be located on the inside two pins.
- B. Second configuration jumper "TEST" allows for control's internal timers to be by-passed for test purposes. Placing jumper on two pins enables test mode.**
- C. Status LED (Light Emitting Diode)**
- LED1 is located on center of board. Series of blinks communicates status of board. Between blink sequence is separation of approximately 2 seconds. Status Code is listed below.

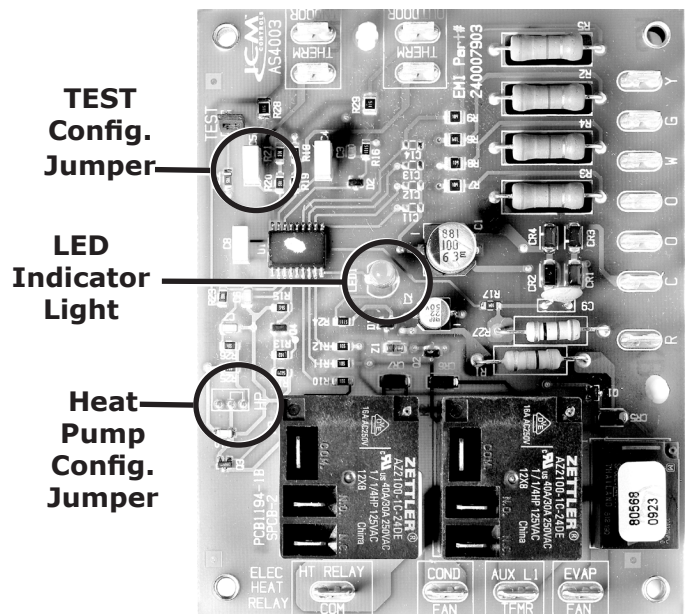
Trouble Code (Blinks)	Status
1	Normal Operation
2	Anti-Short Cycle Timer Active
3	Outdoor Coil Freeze Protection
4	Indoor Coil Freeze Protection
5	Simultaneous "Y" and "W" Call

### Initial Power-Up or Power Restoration

When power is applied to unit, either for first time or after power failure, board will initialize itself.

1. During initialization, LED1 will be lit continuously for approximately 5 seconds.
2. Following initialization, random start timer is initiated. Timer adds randomly selected 5-120 seconds to start-up sequence, reducing possibility of multiple units starting at same time.
3. Once random start timer has expired, 180 second Anti-Short Cycle Timer is initiated and Processor Board Trouble Code LED is set to blink 2 flash code. Timer prevents compressor from rapid cycling.
4. After Anti-Short Cycle Timer expires, Processor Board Trouble Code LED is set to blink 1 blink Trouble Code, indicating normal operation.

**Figure 20 Control Board**



## SEQUENCE OF OPERATION

### R\_\_C / R\_\_H; Cooling Operation

#### ( For unit mount controls)

1. System Switch [SS] set to "Cool", and Fan Cycle Switch [FCS] set to "On" (Continuous Fan Operation), indoor fan motor starts. (Reversing valve energizes heat pump only.)
2. Fan Cycle Switch [FCS] set to "Off" (Cycling Fan Operation), indoor fan motor starts with call for cooling from internal thermostat [T'stat].
3. Units equipped with optional Motorized Fresh Air Damper, and active Fresh Air Switch [FAS], damper opens with call for indoor fan.
4. Room temperature below thermostat setting fan operation continues as noted above.
5. Room temperature above thermostat setting, compressor and outdoor fan start, provided Anti-Short Cycle Timer has timed out from initial power-up, power restoration or previous compressor on cycle. Operation continues until room temperature satisfies thermostat.
6. Once room temperature falls below set point by 3°F (2°C), compressor, outdoor fan motor is de-energized.
7. FCS is set to "Off", indoor fan continues to operate for 60 seconds after compressor stops.
8. If FCS set to "On", indoor fan continues to operate.
9. As soon as compressor is de-energized, Anti-Short Cycle Timer is initialized and prevents compressor from starting again for another 180 seconds.
10. While Anti-Short Cycle Timer is active on call for cooling, Processor Board Trouble Code LED will blink 2 flash code.
11. After Anti-Short Cycle Timer expires, Processor Board Trouble Code LED will blink 1 blink Trouble Code, indicating normal operation.
12. In cooling units will not start if indoor air temperature is 60°F (15.5 °C) or below or if outdoor temperature is below 35°F (1.7°C).

#### Note

Remote-Thermostat Cooling Operation depends on features of wall-mounted thermostat. By default fan will cycle with call for cooling.

For thermostats with **AUTO / ON** fan switch, fan runs continuously if this is "ON" (Continuous Fan Operation). Fan will cycle with call for cooling if this is set to "AUTO" (Cycling Fan Operation).

### R\_\_C / R\_\_H; Heating Operation

1. System Switch [SS] set to "Heat", and Fan Cycle Switch [FCS] set to "On" (Continuous Fan Operation), indoor fan motor starts.
2. If Fan Cycle Switch [FCS] is set to "Off" (Cycling Fan Operation), indoor fan motor starts with call for heat from internal thermostat [T'stat].
3. Unit equipped with optional Motorized Fresh Air Damper, and is active with Fresh Air Switch [FAS], damper opens with call for indoor fan.
4. If room temperature is above thermostat setting fan operation continues as noted above.
5. If room temperature is below thermostat setting, action of unit depends on outdoor temperature and freeze sensor status.

#### • R\_\_H; Mechanical Heating "Heat Pump"

1. Outdoor coil temperature remains about 35 °F (1.7°C), compressor and outdoor fan start provided Anti-Short Cycle Timer has timed out from initial power-up, power restoration or previous compressor on cycle. Operation continues until room temperature satisfies thermostat.
2. Once room temperature rises above set point by 3°F (2°C), compressor and outdoor fan motor will de-energize.
3. FCS set to "Off", indoor fan continues to operate for 60 seconds after compressor stops.
4. FCS set to "On", indoor fan continues to operate.
5. As soon as compressor is de-energized, Anti-Short Cycle Timer initializes and prevents compressor from starting again for another 180 seconds.
6. While Anti-Short Cycle Timer is active on call for heat, Processor Board Trouble Code LED is set to blink 2 flash code.
7. After Anti-Short Cycle Timer expires, Processor Board Trouble Code LED is set to flash 1 blink Trouble Code, indicating normal operation.

#### Note

Remote-Mount Heating Operation depends on features of wall-mounted thermostat. By default fan cycles with call for Heating.

For thermostats with **AUTO / ON** fan switch, fan runs continuously if this is "ON" (Continuous Fan Operation).

Fan cycles with call for heating if this is set to "AUTO" (Cycling Fan Operation).

## SEQUENCE OF OPERATION

### ● **R\_\_H; Auxiliary Heating “Electric” or “Hydronic”**

1. Outdoor coil temperature falls to 35°F (1.7°C) or below for 180 seconds at anytime during heating call, compressor and outdoor fan motor are de-energized and auxiliary heat is energized.
2. Anti-Short Cycle Timer is initiated, prohibiting compressor operation for 180 seconds.
3. Processor Board Trouble Code LED flashes 3 blink Trouble Code, indicating auxiliary heat operation. Heating operation with auxiliary heat continues until outdoor coil sensor reaches 50°F (10°C).

- A. Cooling and Heating operate identical to unit mount controls.
- B. See remote control manuals for control details.
- C. Remote units do not use system switch, or FCS.

### ● **“Electric Heat”**

1. System Switch [SS] set to “Heat”, and Fan Cycle Switch [FCS] set to “On” (Continuous Fan Operation), indoor fan motor will start.
2. Fan Cycle Switch [FCS] set to “Off” (Cycling Fan Operation), indoor fan motor starts with call for heating from internal thermostat [T’sat].
3. Unit equipped with optional Motorized Fresh Air Damper, and activated with Fresh Air Switch [FAS], damper opens with call for indoor fan.
4. Room temperature above thermostat setting fan operation continues as noted above.
5. Room temperature below thermostat setting, electric heater is energized until room temperature satisfies thermostat.
6. Once room temperature increases above set point by 3°F (2°C), electric heaters de-energize.

### ● **“Hydronic Heat”**

1. FCS set to “On” (Continuous Fan Operation) and unit has Control, indoor fan and fresh air motorized damper operation are controlled by Control.
2. With call for heat, signal from processor board activates water or steam valve.
3. Unit equipped with field installed Control [AS], indoor fan start is delayed until hydronic coil reaches 100 ± 5°F (38 ± 3°C) if AS < 80°F, fan shuts off.
4. Signal to water or steam valve continues until room temperature rises above set point by 3°F (2°C).
5. FCS set to “Off”, indoor fan continues to operate for 60 seconds.
6. FCS set to “On”, indoor fan de-energizes if Control senses temperature of 80 ± 5°F (26 ± 3°C) or below.

### ● **“Remote Wall Thermostat Controls”**

### Before Operating Unit

- ❑ Read and understand contents of this manual.
- ❑ Install unit per instructions outlined in this manual and all applicable local and national codes.
- ❑ Verify electrical supply matches electrical requirements of unit, and unit is properly grounded.
- ❑ Examine control box. Verify all wire connections are secure, and control board jumpers are in proper positions. See "Electrical Connections" Page 25.
- ❑ Verify chassis is properly fitted to wall sleeve and securely mounted to surrounding framing.
- ❑ Verify chassis is level:
  - Pour water into drain pan.
  - Verify water flows through drain hoses to condenser side of unit.
- ❑ Verify indoor blower wheels and outdoor fan blades are secured to their motor shafts, and rotate freely.
- ❑ Verify all sheet metal panels are in place and secure.
- ❑ Attach front panel to existing cabinet enclosure.
- ❑ Verify nothing interferes with room discharge air or return air of units. Examples:
  - Check for curtains or drapes that obstruct air flow. See Figures 21 and 22.
  - Check for plush carpeting that can obstruct return air.
  - Items like these can cause serious damage to chassis.
- ❑ Verify unit is sealed to wall sleeve.
- ❑ Verify supply duct is sealed to cabinet grill.

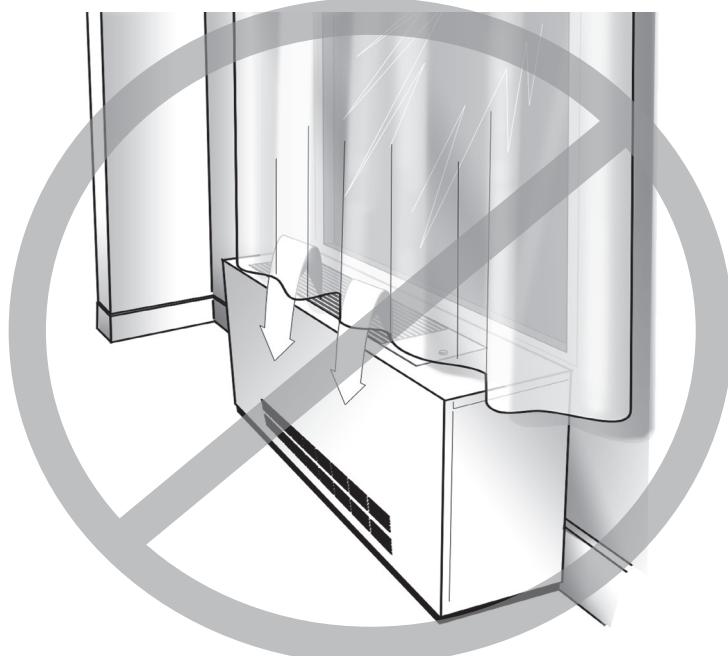
Any obstruction of supply air, including use of deflector baffles, may cause condensate to form on louver or cabinet (see Figure 38, page 31).

**Figure 21 Proper Air Flow Example**



For optimum performance of your PTAC/PTHP, avoid restricting air flow. Position of curtains or drapes over supply air grille may cause air to recirculate without cooling room. Unit will short cycle and may cause premature compressor failure.

**Figure 22 Restricted Air Flow Diagram**



## Electrical Connections

### ⚠ WARNING

Electrical shock hazard. Disconnect all power before removing chassis, performing any cleaning, servicing, or maintenance. Failure to do so could result in death or serious injury

Refer to wiring diagram attached to unit for wiring details. All field wiring shall conform to requirements of authority having jurisdiction or in absence of such requirements:

- United States
  - National Electrical Code, ANSI/NFPA 70
- Canada
  - CSA C22.1 Canadian Electrical Code Part 1.

**UNITS RATED 208/230V** — RetroAire unit is wired for 230V primary voltage from manufacturer.

Transformer must be rewired by installer if job site voltage is 208V.

Change transformer tap from orange to red. See wiring diagram for details.

## Setting Control Board Jumpers

Control board has two sets of factory installed jumper pins on control board, **HP** jumper and **TEST** jumper.

**HP Jumper** — to select heat pump or straight cooling

Pins determine whether unit operates as straight cooling or as heat pump. See Figures 23 and 24.

- Jumper right pin to center pin for heat pump operation.
- Jumper left pin to center pin for straight cooling operation.

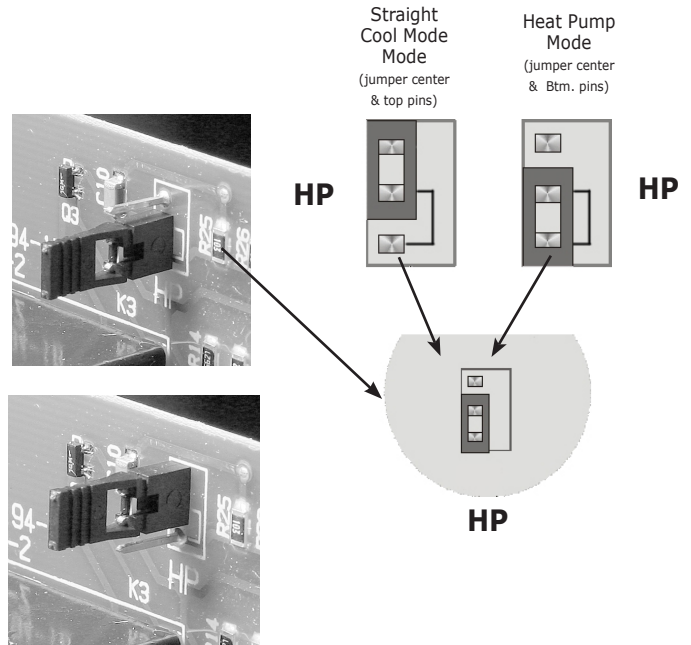
**TEST Jumper** — to select normal or test mode

Jumper is for use in testing only. See Figures 24 and 25.

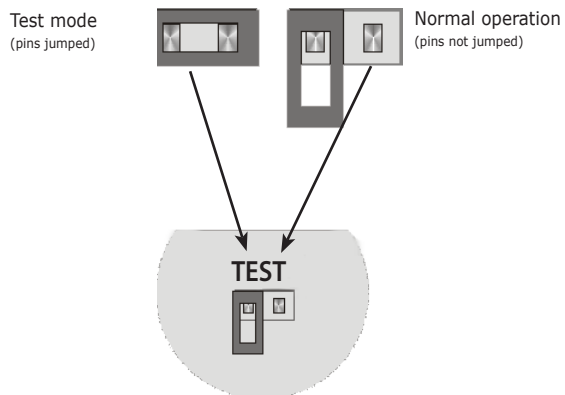
- When **JUMPER** pins are jumped together, all timers are eliminated (example — anti-short cycle, purge, etc.).
- Used mainly used for production line testing. May be used for field testing.
- Units are factory set with jumper on only one pin (normal operation position).

**Note** — Do not leave unit operating with TEST jumper in TEST position.

**Figure 23 TEST Jumper** (selects heat pump or straight cooling)



**Figure 24 TEST Jumper** (selects heat pump or straight cooling)



**Start Up**

1. Verify unit is secure and level.
2. **Heat pump units only** — Verify thermostatic drain pan valve is operating correctly. Valve should be closed if temperature is above 60°F and open if temperature is below 60°F.
3. Test optional fresh air damper. Set damper door switch to **"YES"** position, verify damper opens and allows fresh air to be moved into space. Set damper door switch to **"NO"** position. Verify flow of air into space has stopped. Fresh air will only be available when indoor fan is running.
4. Verify **HP** jumper is set correctly for unit type. See Figure 23, page 25
5. Set **TEST** jumper to **test mode**. Will disable time delays, including anti-short-cycle and purge times. See Figure 25.
6. Verify unit is wired according to instructions, including requirements on page 25.
7. Connect Electric power to unit .
8. Turn on unit to check for proper operation. Check condensate removal by pouring water into base pan, place unit in cooling mode, and with condenser fan running, verify water is picked up by slinger ring and thrown onto outdoor coil.

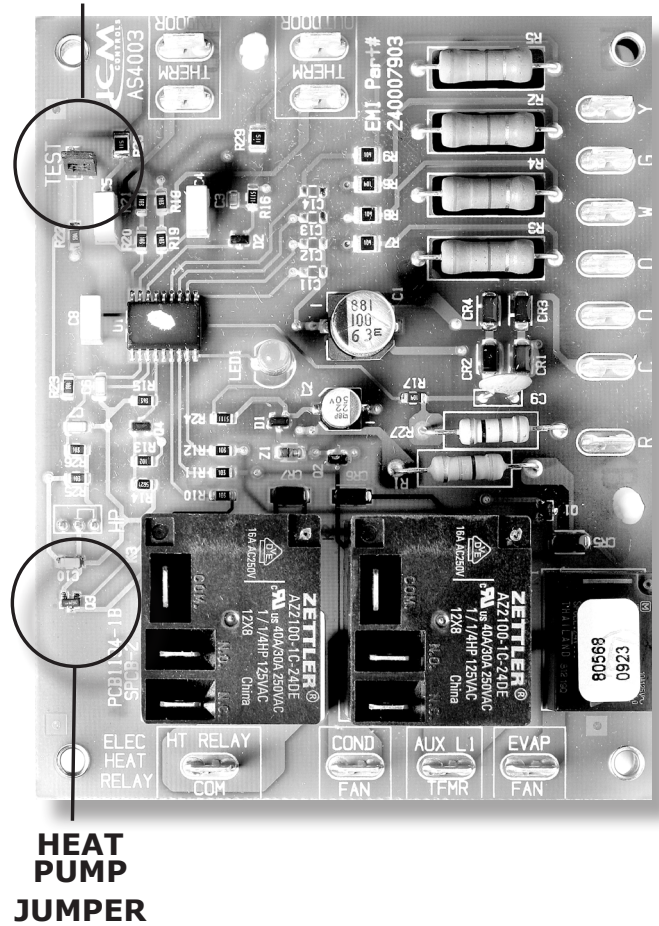
**Note** Compressor will not start until anti-short time period has elapsed. On power-up, there will be delays for control board initialization and random-start timing. See "Sequence of Operation" on page 21.

**Unit-Mounted Thermostat**

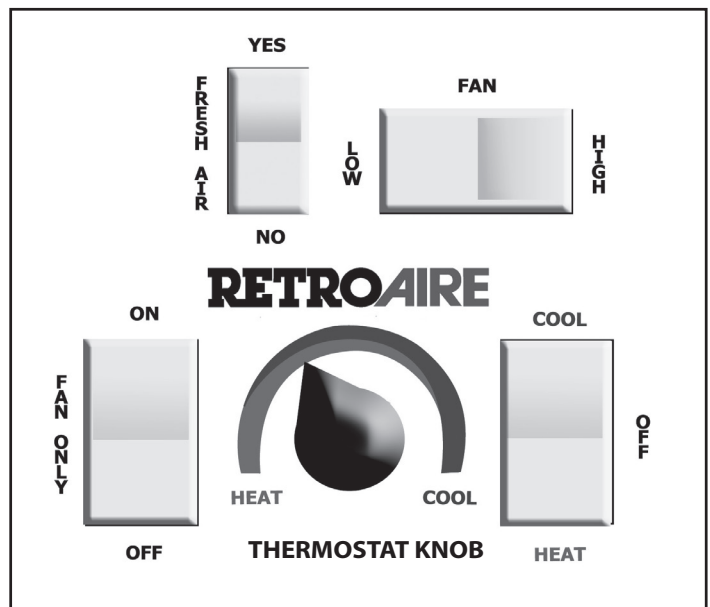
1. Use system switch to place PTAC/PTHP in either **COOL**, **HEAT**, or **OFF** position. See Figure 26. Test operation in all positions.
2. Use fan speed switch to place fan in either **LOW** or **HIGH** speed. Test operation in both positions for heating and cooling.
3. Test operation of Fan Cycle switch (toggle switch on side of control box), with switch set at **ON** (continuous fan operation) or **AUTO** (cycling with thermostat) for both heating and cooling. Set switch in desired position.
4. Rotate thermostat knob to left to increase setpoint temperature, or right to decrease. Turning unit-mounted thermostat knob to far left will produce warmest room temperature, while turning it way to right will produce coolest. Setting can be adjusted for personal comfort.

**Figure 25 Circuit Board**

**TEST JUMPER**



**Figure 26 Mount Control**



## Remote-Mounted Thermostat

1. Use thermostat to place PTAC/PTHP in either **COOL**, **HEAT**, or **OFF** position. Test operation in all positions.
2. If thermostat is fitted with fan switch, set as desired places fan in either **ON**, **OFF**, or **AUTO**. Test operation in all positions.
3. Check thermostat calibration for both heating and cooling operation.

## Straight Cooling PTAC's

### Cooling Cycle

1. Place thermostat or system switch in **COOL** position.
2. Adjust thermostat to cooler temperature until indoor fan starts running. Compressor and outdoor fan should turn on and cold air begin to flow from unit. Let unit continue operating to cool room and remove humidity.
3. After unit starts running and space gets cooler, adjust thermostat to warmer temperature until compressor cycles off.
4. If colder room temperature is desired, adjust thermostat to cooler temperature setting, turning compressor and both fans back on.
5. If warmer room temperature is desired, adjust thermostat to warmer temperature setting. Compressor and outdoor fan stops and indoor fan switches off after sixty-second purge time has elapsed.
6. Place thermostat or system switch in the **OFF** position. All operation should stop.

### Note

Room temperature must be above 65°F (18°C) for compressor to operate in cooling mode on PTAC's with unit mounted controllers.

When unit is first powered up, high humidity conditions can cause condensation to form on discharge grill. Keep doors and windows closed to reduce humidity, condensation will evaporate.

## Heating Cycle — Electric Option

1. Place thermostat or system switch in **HEAT** position.
2. Adjust thermostat for warmer temperature until indoor fan starts running and electric heater coil starts emitting heat.
3. Outdoor fan does not run during heating cycle.
4. After unit starts running and space gets warmer, adjust thermostat to cooler temperature until electric heater turns off.
5. Warmer room temperature is desired, adjust thermostat to warmer temperature setting, turn electric heater back on.
6. Cooler room temperature is desired, adjust thermostat to cooler temperature setting until electric heater turns off. Indoor fan will switch off after sixty-second purge time has elapsed.
7. Place thermostat or system switch in **OFF** position. All operation should stop.

### Note

Room temperature must be below 85°F (29.4°C) to energize heater on PTAC's with unit-mounted controllers.

## Heating Cycle — Hydronic Option

Verify motor valve is rated for correct voltage. RetroAire units with unit mount controls will power hydronic valve that is same voltage as unit (ex: unit rated 208/230V will power 208/230V).

Switch is provided on control box to change from NO to NC. Verify wiring diagram (located on unit) and voltage application for specific unit.

Other valve configurations and voltage options are available. Consult Manufacturer if unit voltage does not match your valve application.

1. Place thermostat or system switch in **HEAT** position.
2. Adjust thermostat to warmer temperature.
  - Signal from processor board activates water or steam valve.
  - Motorized valve opens and allows hot water or steam to run through coil.
  - Indoor fans run, blowing air through hydronic coil. Units equipped with optional aquastat, indoor fan and motorized damper operation will be delayed until hydronic coil reaches 100 ± 5°F (38 ± 3°C).
  - Signal to water or steam valve will continue until room temperature rises above setpoint by 3°F (2°C).

## INSPECTION & START-UP

3. After unit starts running and area is warmer, adjust thermostat to cooler temperature, hydronic valve will close and indoor fan will switch off after sixty-second purge time has elapsed.
4. For warmer room temperature, adjust thermostat to warmer temperature setting, which opens hydronic valve and turns on indoor fan.
5. For cooler room temperature, adjust thermostat to cooler temperature setting. Hydronic valve closes and indoor switches off after sixty-second purge time has elapsed.
6. Place thermostat or system switch in **OFF** position. All operation should stop.

**Note** Room temperature must be below 85°F (29°C) for hydronic heater to operate on PTAC's with unit-mounted controllers.

Hydronic valve is 24Vac normally open valve. Should power be interrupted, valve will default to open position.

### Testing Completion For Cooling-Only PTAC's

If **TEST** jumper was set to **test mode** verify it is set back to **normal operation**. See Figure 24, page 25.

**Note** Do not leave unit operating with TEST jumper in TEST position. Prolonged operation with unit on test mode will cause damage to internal components.

### Heat Pump PTHP's

**Note** Unit equipped with reversing valve energized for cooling and de-energized in heating mode.

### Cooling Cycle — Heat Pump Units

1. Place thermostat or system switch in **COOL** position.
2. Adjust thermostat to cooler temperature until indoor fan starts running. Compressor and outdoor fan turn on and cold air begins to flow from unit. Let unit continue operating to cool room and remove humidity.
3. Unit starts running and space gets cooler, adjust thermostat to warmer temperature until compressor cycles off.
4. Colder room temperature desired, adjust thermostat to cooler temperature setting, turning the compressor and both fans back on.
5. Warmer room temperature desired, adjust thermostat to a warmer temperature. The cooling mode will cease and the compressor and outdoor fan will stop. The indoor fan will switch off after the sixty-second purge time has elapsed.

6. Place thermostat or system switch in **OFF** position. All operation stops.

**Note** Room temperature must be above 85°F (29°C) for compressor to operate in cooling mode on PTHP's with unit-mounted controllers.

7. Place system switch in **OFF** position. All operation stops.

### Heating Operation — Heat Pump Units — Outdoor Temperature Above 35°F (1.7°C)

1. Place thermostat or system switch in **HEAT** position.
2. Adjust thermostat to warmer temperature setting until indoor fan start to run. Compressor and outdoor fan turn on, warm air begins to flow.
3. Unit starts to run and space gets warmer, adjust thermostat to cooler temperature until compressor cycles off.
4. Warmer room temperature, adjust thermostat to warmer temperature setting turning indoor and outdoor fans, and compressor back on.
5. Cooler room temperature is desired, adjust thermostat to cooler temperature setting. Heating mode ceases and compressor and outdoor fan stops. Indoor fan switches off after sixty-second purge time has elapsed.

**Note** Room temperature must be above 85°F (29°C) for compressor to operate in cooling mode on PTHP's with unit-mounted controllers.

6. Place thermostat or system switch in **OFF** position. All operation stops.

**Note** Heat pump units are "Limited Range" equipped with back-up electric resistance heat. Limited Range heat pumps are designed to operate when outdoor temperatures are between 75°F(24°C) and 35°F (1.7°C) and with maximum indoor temperature of 85°F (29°C). When outdoor temperature falls below 35°F (1.7°C) unit will switch from heat pump to electric resistance heat, or optional hydronic heat if selected. Electric heat or hydronic heat will remain heat source until outdoor temperatures rise above 50°F (10°C). RetroAire heat pumps (R\_ \_H) are single-stage heating units. Electric heat and heat pump will NOT operate simultaneously.

### Auxiliary Heating Operation — Heat Pump Units — Outdoor Temperature Below 35°F (1.7°C) — Electric Option

1. Place thermostat or system switch in **HEAT** position.
2. Adjust thermostat to warmer temperature until indoor fans start running and electric coil starts emitting heat.
3. After unit starts running and space warms, adjust thermostat to cooler temperature until electric heater turns off.
4. Warmer room temperature is desired, adjust thermostat to warmer temperature setting, which turns electric heater back on.
5. Cooler room temperature is desired, adjust thermostat to cooler temperature setting until electric heater turns off. Indoor fan switches off after sixty-second purge time has elapsed.
6. Place thermostat or system switch in **OFF** position. All operation stops.

**Note** Room temperature must be below 85°F (29°C) to energize heater on PTHP's with unit-mounted controllers.

**5 kW heat models only** — in event limit switch opens and de-energizes electric heat, reset limit switch manually;

- Turn power off
- Remove control box cover.
- Locate limit switch.
- Push reset button in on the face of the switch. See Figure 27, page 30.

### Auxiliary Heating Operation — Heat Pump Units — Outdoor Temperature Below 35°F (1.7°C) — Hydronic Option

1. Place thermostat or system switch in **HEAT** position.
2. Adjust thermostat to warmer temperature. Following occurs:
  - Signal from processor board activates water or steam valve.
  - Motorized valve opens and allows hot water or steam to run through coil.
  - Indoor fans run, blowing air through hydronic coil
    - Units equipped with optional aquastat, indoor fan and motorized damper operation will be delayed until hydronic coil reaches 100 ± 5°F (38 ± 3°C).
  - Signal to water or steam valve continues until room temperature rises above setpoint by 3°F (2°C).
  - After unit starts running and space gets warmer, hydronic valve closes and indoor fan switches off after sixty-second purge time has elapsed.

3. After unit starts running and space gets warmer, adjust thermostat to cooler temperature setting, hydronic valve closes and indoor fan switches off after sixty-second purge time has elapsed.
4. Desired warmer room temperature, adjust thermostat to warmer temperature setting, which opens hydronic valve and turns on indoor fan.
5. Desired cooler room temperature, adjust thermostat to cooler temperature setting. Hydronic valve closes and indoor fan switches off after sixty-second purge time has elapsed.
6. Place thermostat or system switch in **OFF** position. All operation stops.

**Note** Room temperature must be below 85°F (29°C) for hydronic heater to operate on PTHP's with unit-mounted controllers.

### Completion Of Testing For Heat Pumps

Operation testing is complete. If **TEST** jumper was set to **test mode** verify it is set back to **normal operation** (see Figure 24, page 25).

### Monthly Inspection And Maintenance

#### ⚠ WARNING

Electrical shock hazard. Disconnect power to replacement PTAC/PTHP before servicing or accessing control compartment. Failure to do so could result in severe personal injury or death.

**Note** ▶ It is illegal to discharge refrigerant into atmosphere. Use proper reclaiming methods and equipment when servicing RetroAire replacement PTAC/PTHP.

For optimum performance and reliability of your RetroAire replacement PTAC/PTHP, manufacturer recommends performing the following inspections and maintenance on a monthly basis. Units that are installed in harsh or dirty environments will require more frequent inspections and maintenance.

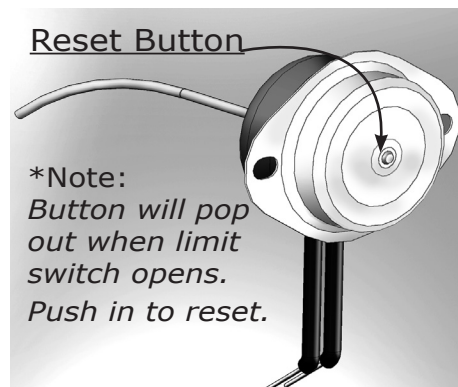
**Disconnect power to unit** and remove access panels.

- ❑ Clean or replace indoor air filter.
- ❑ Vacuum return air grille surface.
- ❑ Inspect & clean chassis interior for rodent or insect infestation.
- ❑ Clean & flush condensate drain pan and chassis base pan.
- ❑ Verify condensate drain is functioning properly, if applicable.
- ❑ Inspect refrigeration tubing, braze joints, for signs of refrigerant leaks (*oil residue*). Repair if necessary.
- ❑ Inspect indoor and outdoor coils. Verify dirt or debris have not collected on fins. Clean if necessary. Take care not to damage coil fins when cleaning. Use fin comb to straighten any bent fins.
- ❑ Examine control box. Verify all wire connections are secure.
- ❑ Verify indoor blower wheels and outdoor fan blades are secured to their motor shafts.
- ❑ Verify dirt or debris have not collected on indoor blower wheels and outdoor fan blades. Use vacuum and soft brush to clean if necessary.
- ❑ Units with hydronic option installed, inspect piping, braze joints, for signs of water leaks. Repair if necessary.
- ❑ Clean exterior cabinet as desired with mild soap or household cleaner.
- ❑ **5 kW heat models only** — in event limit switch opens and de-energizes electric heat, manually reset limit switch.

To manually reset limit switch;

- Remove control box cover.
- Locate limit switch.
- Push reset button in. See Figure 27.

**Figure 27 Manual Reset Limit Switch**



**Note** ▶ Clean or replace return air filter as needed. Allowing dust to collect on filter will cause unit to lose efficiency and eventually malfunction. Check filter at least once month. Some environments may require more frequent replacement, depending on particulate in air stream.

If new air filter is needed for your RetroAire replacement PTAC/PTHP, consult manufacturer for availability and/or proper sizing.

### Seasonal Start-Up And Maintenance

Perform complete mechanical check and maintenance inspections at beginning of cooling and heating season.

**Disconnect power to unit** and remove access panels.

- Perform inspections and maintenance defined in "Monthly Start-Up And Maintenance."
- Visually check equipment. Look for changes in unit such as damaged coils or evidence of extended wear on any moving parts.
- Check for unusual odors, oil leaks, or stains on or around coil and refrigerant lines. Presence of oil may indicate potentially serious problem such as refrigerant leak (*example — burned motor windings, water, or refrigerant*).
- Verify base pan is clean.
- Inspect all electrical connections. Look for frayed wires and poor connections. Terminal ends that are loose will eventually fail, causing loss of performance or worse.
- Check fan motors and blower assemblies. Some units may require drop of light oil to motors and/or bearing assemblies (*look for oil cups*). Verify set-screws and motor mounting hardware are secure.

## MAINTENANCE

- Brush and/or vacuum centrifugal fan blades and blower cage assemblies.
- Inspect both indoor and outdoor coils. Use fin comb to straighten any damaged fins. Coils must be clean for proper operation.

**Note** Do not use solvent-based cleaner to clean coils, some solvents will produce noxious odor when unit is operating.

- Look for oil leaks or stains on or around all braze joints and refrigerant lines. Presence of oil indicates potentially serious problem (*such as a refrigerant leak*).
- Inspect and clean drain pan and drain line(s). Use of anti-fungicide tablet to keep condensate system free from bacterial contaminants is recommended.
- Verify unit pitch. Building and equipment may settle, causing shift in direction of condensate flow. Unit should pitch minimum of 5° (*at least 1/2"*) to outside allowing for proper drainage.
- Check weep holes along rear flange of base pan to ensure free of debris.
- Check seal around unit is not broken or damaged.

**Note** Air leaks make conditioned area uncomfortable drafty or produce noise. Visually inspect foam gasket between wall and unit, taking note of separation between air inlet for condenser and condenser coil discharge. These areas must be sealed off from each other. If you experience poor cooling operation or erratic operation, check for air recirculation at condenser coil.

- Replace access panels and reconnect electrical power.
- Test unit operation.

### Heat Pump Units — *Temporary Emergency Heating Mode*

Heat pump failure, control board can be forced into electric heat mode. **This is temporary solution until heat pump system is repaired.**

- Locate circuit board in control section of unit.
- Locate terminals where outdoor sensor connects to circuit board.
- Use small needle nose type pliers, disconnect one side of sensor from circuit board. 2-stage thermostat will provide Emergency heat.
- Circuit board sees this as outdoor coil freeze condition energizing electric resistance heater on call for heat.
- See "Manual Reset Limit Switch". See Figure 27, page 30 to reset limit switch if needed.

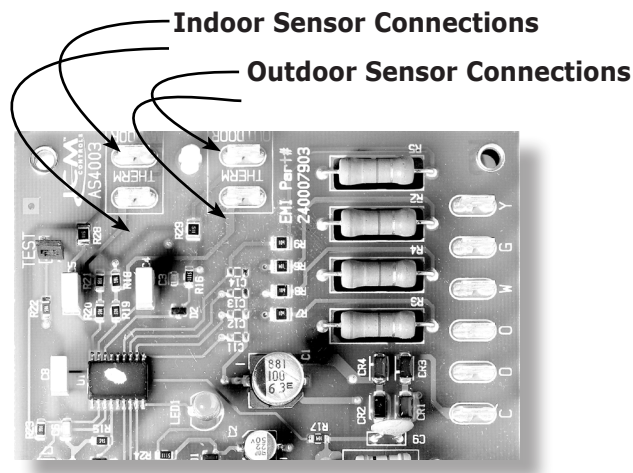
### Troubleshooting Sensors

1. See Figure 28 for location of sensor connections to control board.
2. If temperature response of indoor or outdoor sensor is not correct, disconnect sensor from control board and check sensor resistance. Replace sensor if resistance is not close to values in Table 3.

**Table 3 Sensor Resistance Values**

	Resistance, K ohms
77 (25°C)	10.0 K
50 (10°C)	19.9 K
35 (1.6°C)	30.0 K
30 (-1.1°C)	34.4 K

**Figure 28 Sensor Connections On Control Board**



## TROUBLESHOOTING

### Troubleshooting

### **WARNING**

Fire, explosion, and electrical shock hazard. Troubleshooting procedures shall be conducted by a qualified technician. Improper installation could result in death or serious injury.

Symptom	Suggestion
No heat or cooling	<ul style="list-style-type: none"> <li>Verify unit has power and thermostat is satisfied. If thermostat is not satisfied, call your installing contractor or service contractor.</li> </ul>
Thermostat calls for cooling, no cool air is coming from unit.	<ul style="list-style-type: none"> <li>Verify continuity between thermostat and unit. Verify 24 Vac is present across terminals <b>C</b> and <b>R</b>.</li> <li>Check outdoor coil for dirt debris, remove any foreign material. Locate high pressure switch reset button and push button.</li> <li>Some units are equipped with <b>LCDI</b> (Leakage Current Detection Interrupt) line cord. Verify line cord is reset by pressing reset button at line cord plug.</li> </ul> <p><b>Note:</b> If evaporator fan is operational and above suggested procedures have been followed, and there is no cooling being supplied by unit, contact trained heating and cooling professional.</p>
Light on circuit board is blinking.	<p>Circuit board uses light for diagnostic purposes. Code determination:</p> <ul style="list-style-type: none"> <li>1 blink = normal operation</li> <li>2 blinks = compressor lockout (ASCT — Anti-Short Cycle Timer)</li> <li>3 blinks = outdoor freeze condition</li> <li>4 blinks = indoor freeze condition</li> <li>5 blinks = simultaneous Y and W call</li> </ul>
Circuit board light is blinking 3 or 4 times, there is no freeze condition.	<ul style="list-style-type: none"> <li>Verify sensors have not been damaged.</li> <li>Remove sensor wires from control board and take resistance measurements, compare to following sensor resistances. Indoor and outdoor coil sensor wires and control board are labeled.</li> <li>Verify sensors are correctly wired.</li> </ul> <p>77°F = 10KOhms                      50°F = 19.9KOhms                      35°F = 30KOhms                      30°F = 34.4KOhms</p>
Thermostat is satisfied, fan is still running.	<ul style="list-style-type: none"> <li>Thermostat set to Auto mode, once thermostat is satisfied, fan stays energized for extra 60 seconds to purge unit of excess cool or warm air in plenum.</li> <li>If thermostat fan switch is set to <b>ON</b>, fan stays energized regardless of thermostat being satisfied or not. To turn fan off turn unit off or turn thermostat fan switch to <b>AUTO</b>.</li> </ul>
Thermostat calls for heat, no heat comes from unit.	<p>Units equipped with electric heaters have temperature limit switch to prevent electric heater from reaching unsafe temperatures. After calling for heat, heater is not energized, check for continuity across limit. If limit is open, replace with equivalent limit switch. Auto reset / Manual reset Switch (Requires trained professional)</p>
Thermostat calls for heat while in heat pump mode, heated air is not coming from unit.	<ul style="list-style-type: none"> <li>Verify unit has power or thermostat has been satisfied. If unit has power and thermostat is satisfied, turn thermostat few degrees above room temperature.</li> <li>Verify <b>LCDI</b> line cord has not tripped.</li> <li>Verify thermostat while in heat pump mode is not energizing <b>O</b> terminal. RetroAire units are designed to work in heat pump mode when 24vac is present across <b>Y</b> and <b>C</b>.</li> <li>Verify heat pump jumper on control board is jumping two pins labeled "<b>HP</b>". See control board jumper locations, Figure 23, page 25.</li> <li>Verify there are no freeze conditions. See "Circuit board light is blinking" above for more information.</li> </ul>

## HYDRONIC HEAT PERFORMANCE

**Table 4 R10 | R20 | R35 C/H hydronic heat \* — performance 104-101 (single row coil)**

Model	Hydronic Coil Code Part Number	Air Entering Dry Bulb		Air Entering Wet Bulb		Air Entering Flow Rate		Water Flow		Water Entering		Capacity		Pressure Drop		Water Leaving		Water Delta							
		°F	°C	°F	°C	CFM	m³/min	GPM	LPM	°F	°C	Btu/h	kW	ft H2O	m H2O	°F	°C	°F	°C						
R10 R35	104 000 130	70	21	56	13	450	12.7	2.9	11.1	180	82	14,300	4.2	2.8	0.8	170	77	10	6						
						400	11.3	2.8	10.4	180	82	13,500	4.0	2.5	0.8	170	77	10	6						
						450	12.7	1.7	6.4	140	60	8,400	2.5	1.1	0.3	130	54	10	6						
						400	11.3	1.6	6.1	140	60	7,900	2.3	1.0	0.3	130	54	10	6						
						450	12.7	3.0	11.4	180	82	14,400	4.2	2.9	0.9	170	77	10	5						
						400	11.3	3.0	11.4	180	82	13,600	4.0	2.9	0.9	171	77	9	5						
						450	12.7	3.0	11.4	140	60	9,000	2.6	3.1	0.9	134	57	6	3						
						400	11.3	3.0	11.4	140	60	8,600	2.5	3.1	0.9	134	57	6	3						
						450	12.7	2.0	7.6	180	82	13,700	4.0	1.4	0.4	166	74	14	8						
						400	11.3	2.0	7.6	180	82	13,000	3.8	1.4	0.4	167	75	13	7						
						450	12.7	2.0	7.6	140	60	8,600	2.5	1.5	0.5	131	55	9	5						
						400	11.3	2.0	7.6	140	60	8,200	2.4	1.5	0.5	132	55	8	5						
						450	12.7	1.0	3.8	180	82	12,100	3.5	0.4	0.1	155	68	25	14						
						400	11.3	1.0	3.8	180	82	11,500	3.4	0.4	0.1	156	69	24	13						
						450	12.7	1.0	3.8	140	60	7,500	2.2	0.4	0.1	125	52	15	9						
						400	11.3	1.0	3.8	140	60	7,200	2.1	0.4	0.1	125	52	15	8						
						R20	104 000 101	70	21	56	13	450	12.7	4.3	16.1	180	82	20,800	6.1	7.0	2.1	170	77	10	6
												400	11.3	4.0	15.1	180	82	19,400	5.7	6.2	1.9	170	77	10	6
												450	12.7	2.5	9.3	140	60	12,100	3.5	2.8	0.8	130	54	10	6
												400	11.3	2.3	8.7	140	60	11,300	3.3	2.5	0.7	130	54	10	6
450	12.7	3.0	11.4	180	82							19,900	5.8	3.7	1.1	166	75	14	8						
400	11.3	3.0	11.4	180	82							18,800	5.5	3.7	1.1	167	75	13	7						
450	12.7	3.0	11.4	140	60							12,500	3.7	4.0	1.2	132	55	9	5						
400	11.3	3.0	11.4	140	60							11,800	3.5	4.0	1.2	132	56	8	4						
450	12.7	2.0	7.6	180	82							18,700	5.5	1.8	0.5	161	72	19	11						
400	11.3	2.0	7.6	180	82							17,700	5.2	1.8	0.5	162	72	18	10						
450	12.7	2.0	7.6	140	60							11,700	3.4	1.9	0.6	128	53	12	7						
400	11.3	2.0	7.6	140	60							11,100	3.3	1.9	0.6	129	54	11	6						
450	12.7	1.0	3.8	180	82							15,800	4.6	0.5	0.2	148	64	32	18						
400	11.3	1.0	3.8	180	82							15,100	4.4	0.5	0.2	149	65	31	17						
450	12.7	1.0	3.8	140	60							9,800	2.9	0.6	0.2	120	49	20	11						
400	11.3	1.0	3.8	140	60							9,400	2.8	0.6	0.2	121	49	19	11						

## ELECTRICAL SPECIFICATIONS

**Table 5 R10, R20, R35, - 9.000 Btu Electrical Specifications**

Power Supply Volt — 1-60		Compressor		Indoor Fan Motor		Outdoor Fan Motor		Electric Heat				Unit Electrical Ratings				
Volt	Min	RLA	LRA	FLA	Hp	FLA	Hp	Htr #	Volt	W	HA	TCA	THA	MCA	MOCP	Plug
115V	104	8.0	45.6	1.4	0.09	1.6	0.125	N/A	N/A	N/A	N/A	11	N/A	13.0	20	5-15P
*208/ 230V	197	3.9	20	0.6	0.08	0.71	0.09	0	N/A	N/A	N/A	5.2	N/A	6.2	15	6-15P
								2	208	1636	7.9		8.5	10.6	15	6-15P
									230	2000	8.7		9.3	11.6		
								3	208	2454	11.8		12.4	15.5	20	6-20P
									230	3000	13		13.6	17.1		
								4	208	3271	15.7		16.3	20.4	25	6-30P
									230	4000	17.4		18	22.5		
								5	208	4089	19.7		20.3	25.3	30	6-30P
									230	5000	21.7		22.3	27.9		
								**208/ 230V	197	4.0	22.2		0.6	0.08	0.71	0.09
265V	240	3.32	18.8	0.67	0.08	0.71	0.09	0	N/A	N/A	N/A	4.7	N/A	5.5	15	7-20P
								2	265	2655	10		10.7	13.4		
									3	265	3983		15	15.7	19.6	20
								4	265	5310	20		20.7	25.9	30	7-30P
								5	N/A	N/A	N/A		N/A	N/A	N/A	N/A

\* Toshiba Compressors

\*\* Tecumseh Compressors

## ELECTRICAL SPECIFICATIONS

**Table 6 R10, R20, R35 - 12,000 BTU Electrical Specifications**

Power Supply Volt — 1-60		Compressor		Indoor Fan Motor		Outdoor Fan Motor		Electric Heat				Unit Electrical Ratings					
Volt	Min	RLA	LRA	FLA	Hp	FLA	Hp	Htr #	Volt	W	HA	TCA	THA	MCA	MOCP	Plug	
*208/ 230V	197	5.4	26	0.6	0.08	0.71	0.09	0	N/A	N/A	N/A	6.7	N/A	6.2	15	6-15P	
								2	208	1636	7.9		8.5	10.6	15	6-15P	
									230	2000	8.7		9.3	11.6			
								3	208	2454	11.8		12.4	15.5	20	6-20P	
									230	3000	13		13.6	17.1			
								4	208	3271	15.7		16.3	20.4	25	6-30P	
									230	4000	17.4		18	22.5			
								5	208	4089	19.7		20.3	25.3	30	6-30P	
									230	5000	21.7		22.3	27.9			
								**208/ 230V	197	5.6	29		0.6	0.08	0.71	0.09	0
2	208	1636	7.9	8.5	10.4	15	6-15P										
	230	2000	8.7	9.3	11.5												
3	208	2454	11.8	12.4	15.3	20	6-20P										
	230	3000	13	13.6	16.9												
4	208	3271	15.7	16.3	20.3	25	6-30P										
	230	4000	17.4	18	22.3												
5	208	4089	19.7	20.3	25.2	30	6-30P										
	230	5000	21.7	22.3	27.8												
265V	240	4.6	20	0.67	0.08	0.71	.09					0					N/A
								2	265	2655	10	10.7	13.4				
								3	265	3983	15	15.7	19.6	20			
								4	265	5310	20	20.7	25.9	30	7-30P		
								5	N/A	N/A	N/A	N/A	N/A	N/A	N/A		

\*Toshiba Compressors

\*\*Tecumseh Compressors

## ELECTRICAL SPECIFICATIONS

**Table 7 R10, R20, R35 - 15,000 BTU Electrical Specifications**

Power Supply Volt 1-60		Compressor		Indoor Fan Motor		Outdoor Fan Motor		Electric Heat			Unit Electrical Ratings					
Volt	Min	RLA	LRA	FLA	Hp	FLA	Hp	Htr #	Volt	W	HA	TCA	THA	MCA	MOCP	Plug
*208/ 230V	197	7.65	40	0.6	0.08	0.71	0.09	0	N/A	N/A	N/A	8.7	N/A	10.9	15	6-15P
								2	208	1636	7.9		8.5	10.6	15	6-15P
									230	2000	8.7		9.3	11.6		
								3	208	2454	11.8		12.4	15.5	20	6-20P
									230	3000	13		13.6	17.1		
								4	208	3271	15.7		16.3	20.4	25	6-30P
									230	4000	17.4		18	22.5		
								5	208	4089	19.7		20.3	25.3	30	6-30P
									230	5000	21.7		22.3	27.9		
								**208/ 230V	197	7.4	33		0.6	0.08	0.71	0.09
2	208	1636	7.9	8.5	10.4	15	6-15P									
	230	2000	8.7	9.3	11.5											
3	208	2454	11.8	12.4	15.3	20	6-20P									
	230	3000	13	13.6	16.9											
4	208	3271	15.7	16.3	20.3	25	6-30P									
	230	4000	17.4	18	22.3											
5	208	4089	19.7	20.3	25.2	30	6-30P									
	230	5000	21.7	22.3	27.8											
265V	240	6	28	0.67	0.08	0.71	0.09					0				
								2	265	2655	10	10.7	13.2			
								3	265	3983	15	15.7	19.5	20		
								4	265	5310	20	20.7	25.7	30	7-30P	
								5	N/A	N/A	N/A	N/A	N/A	N/A	N/A	

















\* Toshiba Compressors

\*\* Tecumseh Compressors

## ELECTRICAL SPECIFICATIONS

**Table 8 R10, R20, R35 - 18,000 BTU Electrical Specifications**

Power Supply Volt — 1-60		Compressor		Indoor Fan Motor		Outdoor Fan Motor		Electric Heat			Unit Electrical Ratings					
Volt	Min	RLA	LRA	FLA	Hp	FLA	Hp	Htr #	Volt	W	HA	TCA	THA	MCA	MOCP	Plug
208/ 230V	197	8.3	44	0.6	0.08	0.71	0.09	0	N/A	N/A	N/A	9.6	N/A	10.9	15	6-15P
								2	208	1636	7.9		8.5	10.6	15	6-15P
									230	2000	8.7		9.3	11.6		
								3	208	2454	11.8		12.4	15.5	20	6-20P
									230	3000	13		13.6	17.1		
								4	208	3271	15.7		16.3	20.4	25	6-30P
									230	4000	17.4		18	22.5		
								5	208	4089	19.7		20.3	25.3	30	6-30P
									230	5000	21.7		22.3	27.9		
								265V	240	8.3	44		0.67	0.08	0.71	0.09
2	265	2655	10	10.7	13.2											
3	265	3983	15	15.7	19.5	20										
4	265	5310	20	20.7	25.7	30	7-30P									
5	N/A	N/A	N/A	N/A	N/A	N/A	N/A									

VOLTAGE	125V		250V			265V		
	15(A)	20(A)	15(A)	20(A)	30(A)	15(A)	20(A)	30(A)
PLUG	 5-15 P	 5-20 P	 6-15 P	 6-20 P	 6-30 P	 7-15 P	 7-20 P	 7-30 P
RECEPTACLE	 5-15 R	 5-20 R	 6-15 R	 6-20 R	 6-30 R	 7-15 R	 7-20 R	 7-30 R





## LIMITED PRODUCT WARRANTY

**RetroAire** offers to the original purchaser/owner that under normal use and maintenance for comfort cooling and conditioning applications, all **RetroAire** equipment will be free from defects in material and workmanship for a period of 12 months from the documented date of original installation or 18 months from the date of manufacture, if the documented date of original installation is not available. Unit compressors shall be free from defects in materials and workmanship under normal use and maintenance for a period 60 months from the documented date of original installation or 66 months from the date of manufacture, if the documented date of original installation is not available.

### **WHAT RETROAIRE WILL WARRANT:**

ECR will provide a replacement for or, at the discretion of **RetroAire**, repair any functional component that proves to be defective in material or workmanship, under normal maintenance and operating conditions, within the prescribed warranty period. Said parts will be supplied via standard shipping; billed and then credited back, when the defective component is returned, at the sole discretion of **RetroAire**. However, the replacement cost shall NOT include labor or service costs to diagnose, remove, or install a warranty part, or return of defective materials, at the sole discretion of **RetroAire**.

### **WHAT RETROAIRE WILL NOT WARRANT:**

Damages to or arising from: misapplication, improper installation or service; components not supplied or approved by **RetroAire**, including, without limitation, cabinetry, wall sleeves, louvers, internal components, equipment, or controls supplied by others; and lack of preventative maintenance such as, but not limited to, replacing air filters, general cleaning, clearing condensate drains, air flow adjustments; products manufactured or distributed by **RetroAire** but installed outside the United States and Canada; unauthorized alteration, application or improper operation; excessively corrosive installation environments; equipment usage during construction; shipping or handling.

### **RETROAIRE IS ALSO NOT RESPONSIBLE FOR:**

Damages caused by faulty or interrupted power supply or electrical service; Damages caused by acts of God including, but not limited to, wind, hail, floods, lightning, earthquakes or other conditions beyond the control of **RetroAire**.

### **FURTHER LIMITATIONS:**

All implied warranties of merchantability and/or fitness for any particular purpose are limited in duration to the period of the limited warranty. The rights and remedies provided herein are exclusive and constitute the entire contract. This limited warranty and any optional extended warranties are granted only to the original owner/user. This warranty becomes null and void if payment for the goods or product is in default. Warranty remedies may be withheld if the customer account is in arrears or default.

In no event shall RetroAire be liable (whether for breach of this limited warranty or contract, for strict liability for negligence, or otherwise), for any special, incidental, punitive or consequential damages, including, without limitation, damages for loss of profits, loss of goodwill, loss of time or convenience, loss of use of the product, the cost of a product rental, costs of gasoline, electricity, telephone, travel or lodging, or the loss of personal or commercial property, whether or not RetroAire has been advised of the possibility of any such damages.

In no event shall RetroAire's obligations under this limited warranty exceed the purchase price of the product.

Any repairs performed under this limited warranty shall not in any way extend the statute of limitations for claims under this limited warranty.

No agent, representative or distributor of RetroAire has any authority to alter the terms of this limited warranty in any way.

For Service or Repair:

- 1) Contact the installing contractor
- 2) Call the nearest RetroAire sales rep/distributor
- 3) Call, E-Mail or write:

**RetroAire**, c/o ECR International, Inc., 2201 Dwyer Avenue, Utica, NY 13501, Ph: 1-800-325-5479  
Fax: 1-866-432-7329, E-Mail: [info@RetroAire.com](mailto:info@RetroAire.com), Web: [www.RetroAire.com](http://www.RetroAire.com).



**RETROAIRE™**



**ECR** *international*  
EST. 1928  
A Family of Heating & Cooling Brands.

ECR International Inc  
2201 Dwyer Avenue  
Utica, NY 13501  
(800) 325-5479  
web site: [www.RetroAire.com](http://www.RetroAire.com)