



LRF

Lowboy Rear Flue Model

LRFV

Lowboy Rear Flue Model with ECM Blower

Oil Fired Warm Air Furnaces

**INSTALLATION, OPERATION &
MAINTENANCE MANUAL**



Manufactured by:
ECR International Inc.
2201 Dwyer Avenue, Utica, NY 13501
Tel. 800 253 7900
www.ecrinternational.com
PN 240011511 REV. E [03/15/2018]

DIMENSIONS

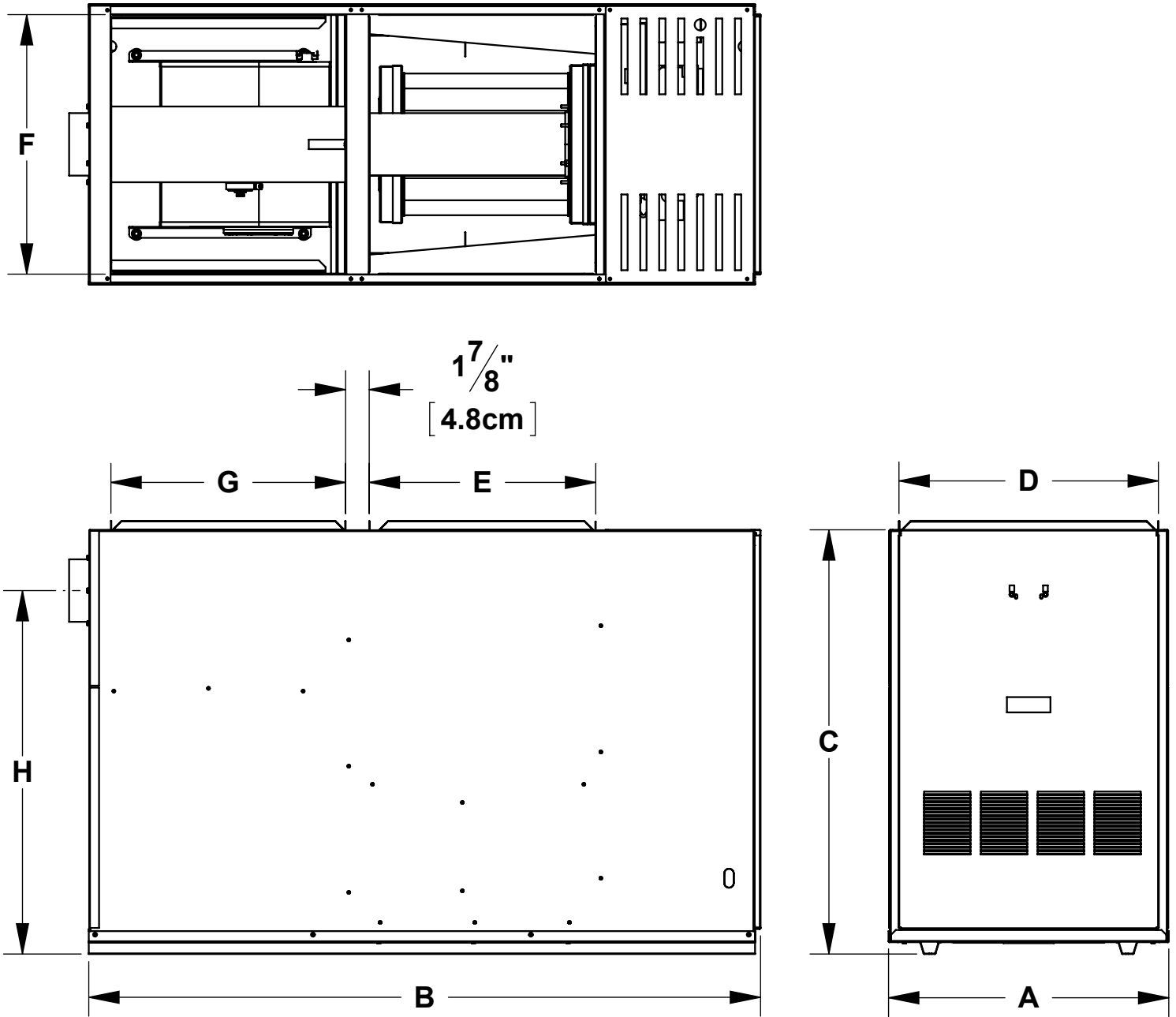

Table 1 - Dimensions

Furnace Model	Cabinet			Plenum - Openings		Flue		Filter (Permanent)	Shipping Weight
	Width A	Length B	Height C	Supply D x E	Return F x G	Diameter	Height H		
LRF/ LRFV	22"	53-1/2"	33-5/8"	20-1/2" x 18"	20-1/2" x 18-5/8"	5"	29"	20" x 20" x 1"	240 LB
	55.8 cm	135.9 cm	85.4 cm	52.1 cm x 45.7cm	52.1 cm x 47.3cm	12.7 cm	73.7cm	51cm x51cm x 2.5cm	108Kg

1. General	4
2. Safety Symbols	4
3. Introduction Models LRF/LRFV	4
4. Heat Loss	4
5. Locating the Unit	5
6. Furnace Used In Conjunction With Air Conditioning.....	5
7. Air Filter	6
8. Ductwork.....	6
9. Combustion and Ventilation Air	6
10. Chimney Venting.....	6
11. Barometric Damper Control	6
12. Optional Direct Venting	6
13a. Fan Timer Board And Limit Control (LRF) [See Figure 2, page 15]	6
13b. Fan Timer Board And Limit Control (LRFV) [See Figure 3, page 15]	7
14. Electrical Connections	7
15. Humidifier.....	7
16. Piping Installation	7
17. Oil Filter	7
18. Oil Burner Nozzles.....	8
19. Oil Burner Adjustment	8
20. Burner Electrodes.....	8
21. Burner Primary (Safety) Control.....	8
22a. Circulating Air Blower (LRF/LRFV)	8
22b. Circulating Air Blower (LRFV)	9
23. Maintenance And Service	9
24. Operating Instructions (LRF).....	10
25. Operating Instructions (LRFV).....	10
Appendix A - Checkout and Adjustments.....	11
A.1 Oil Burner Air Adjustment.....	13
A.2 Burner Electrodes.....	13
A.3 Start Up.....	14
A.4 Final Checkout	14
A.5 Blower Setup	16
Appendix B - Wiring Diagrams.....	18
Chimney Vent Furnace Wiring Diagram LRF/LRFV	19
Direct Vent Furnace Wiring Diagram LRF/LRFV.....	20
Appendix C - Sequence of Operation and Troubleshooting	21
C.1 Troubleshooting	23
C.2 Preliminary Steps:.....	23
C.3 Check Oil Primary Control.....	23
Appendix D - Home Owners Reference Table.....	27
Parts Listing: Chimney Vent Models LRF/LRFV	28
Parts Listing: Direct Vent Models LRF/LRFV	30
Parts Diagram	31

Check our website frequently for updates: www.ecrinternational.com

Information and specifications outlined in this manual in effect at the time of printing of this manual. Manufacturer reserves the right to discontinue, change specifications or system design at any time without notice and without incurring any obligation, whatsoever.

1. General

Furnace installation shall be completed by qualified agency. See glossary for additional information.

WARNING

Fire, explosion, asphyxiation and electrical shock hazard. Improper installation could result in death or serious injury. Read this manual and understand all requirements before beginning installation.

WARNING

Fire, burn, asphyxiation hazard. Do not use gasoline, crank case oil, or any oil containing gasoline. Failure to follow these instructions could result in death or serious injury.

2. Safety Symbols

Become familiar with symbols identifying potential hazards.



This is the safety alert symbol. Symbol alerts you to potential personal injury hazards. Obey all safety messages following this symbol to avoid possible injury or death.

DANGER

Indicates a hazardous situation which, if not avoided, WILL result in death or serious injury

WARNING

Indicates a hazardous situation which, if not avoided, could result in death or serious injury.

CAUTION

Indicates a hazardous situation which, if not avoided, could result in minor or moderate injury.

NOTICE

Used to address practices not related to personal injury.

3. Introduction Models LRF/LRFV

Models LRF and LRFV are oil fired forced air lowboy furnaces with an output capacity range of 65,000 BTU/hr to 100,000 BTU/hr.

- LRF may be equipped with either 1/2 HP PSC 4 speed direct drive or single speed belt drive blower motor.
- LRFV is equipped with 1/2 HP ECM variable speed blower motor.
- Furnaces are factory equipped for chimney venting or factory equipped for direct venting.
 - » Chimney vent and direct vent models are not field convertible.
 - » Supplemental direct vent installation instructions are included with direct vent models.

Installation shall conform to requirements of authority having jurisdiction or in absence of such requirements:

- Canada - CAN/CSA - B139, Installation Code for Oil-Burning Equipment.
- United States - National Electrical Code, NFPA31, Standard for the Installation of Oil-Burning Equipment.

Models are CSA listed, (NRTL/C) for use with No. 1 (Stove) and No. 2 (Furnace) Oil.

Refer to tables in Appendix A for performance data.

4. Heat Loss

Maximum hourly heat loss for each heated space shall be calculated in accordance with the procedures described in the manuals of:

- Canada - The Heating, Refrigeration and Air Conditioning Institute of Canada (HRAI), or by other means prescribed, or approved by the local authority having jurisdiction.
- United States - Manual J, titled, "Load Calculation" published by the Air Conditioning Contractors of America, describes a suitable procedure for calculating maximum hourly heat loss.

⚠ WARNING

Fire hazard. Do not install furnace on tiled floors or carpeting. Failure to follow these instructions could result in death or serious injury.

5. Locating the Unit - [See Table 2]

- Locate furnace so flue connection to chimney is short, direct and consists of as few elbows as possible.
- Centralize furnace location with respect to supply and return air ductwork. Central location minimizes trunk duct sizing.
- All models may be installed on combustible floors.
- Do not install furnace on carpet or tiled floors.

Maintain all clearances to combustibles. See Table 2.

Table 2: Minimum Installation Clearances

Location	Clearance to Combustibles
	LRF and LRFV
Top	1" (26mm)
Bottom	0"
Plenum	1" (26 mm)
Rear	6" (152 mm)*
Sides	1" (26 mm)**
Front	1" (26 mm) *
Flue Pipe	5" (127 mm)
Enclosure	Closet
* 24" (610 mm) Service Clearance	
** 18" (457 mm) required from on side for access to rear	

6. Furnace Used In Conjunction With Air Conditioning

- Install furnace in parallel with or upstream from evaporator coil to avoid condensation in heat exchanger.
- When installed in parallel, prevent chilled air from entering furnace by use of dampers or other air controlling means.
- Manually operated dampers must have a control to prevent operation of either system unless dampers are in full heat or full cool position.
- Air heated by the furnace shall not pass through evaporator coil unless coil is specifically approved for such service.
- Check and adjust blower speed to compensate for pressure drop caused by evaporator coil.
- Maintain required clearance between bottom of coil drain pan and top of heat exchanger as specified by coil manufacturer.
- Cased evaporator coils with cases that are slightly larger than the furnace cabinet may be used by employing field fabricated block off plates to close gap between furnace cabinet and coil casing. See Figures 1a and 1b.
- Cased evaporator coils with cases that are smaller than the furnace cabinet should not be used as they will restrict airflow.

FIGURE 1a: Evaporator Coil

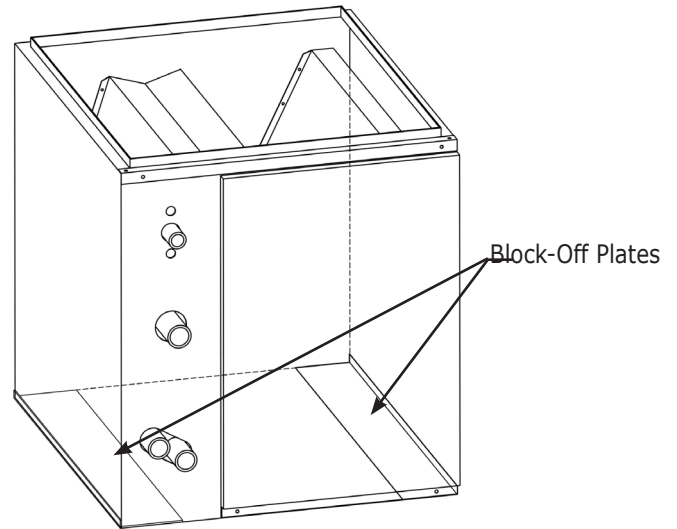
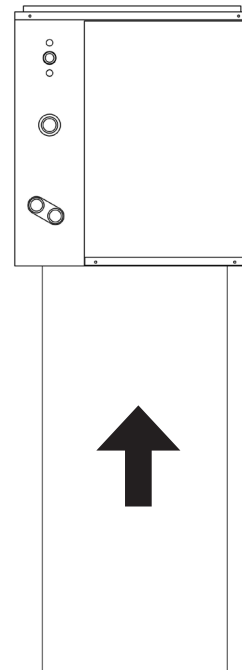

FIGURE 1b: Evaporator Coil Centered Over Narrow Furnace



7. Air Filter

- Install properly sized air filter on return air side of unit.
- Furnace is supplied with 20" x 20" permanent air filter and filter slot in blower compartment.
- If filter is damaged, replace with filter of same size and type.

8. Ductwork

- Supply and return air ductwork must be designed and installed in accordance with approved methods, local and national codes as well as good trade practices.
- When ductwork supplies air to space other than where furnace is located, return air must be sealed and directed to this space.

9. Combustion and Ventilation Air

Comply with CSA B139 (Canada) or NFPA 31 (US) standards for the Installation of Oil Burning Equipment and applicable provisions of local building codes to provide combustion and ventilation air.

⚠ WARNING

Failure to provide adequate combustion and ventilation air could result could result in death or serious injury.

⚠ WARNING

Asphyxiation hazard. Chimney vented versions of furnace must be connected to flue having sufficient draft at all times. Failure to follow these instructions could result in death or serious injury.

NOTICE

This furnace is approved for use with Type L vent or equivalent. Maximum vent temperature for Type L vent is 575°F (300°C).

10. Chimney Venting

- Flue pipe should be as short as possible with horizontal pipes sloping upward toward the chimney at a rate of one-quarter inch per foot.
- Flue pipe should not be smaller in cross sectional area than flue collar on the furnace.
- Flue pipe should connect to chimney so the flue pipe extends into, and terminates flush with the inside surface of chimney liner. Seal the joint between pipe and lining.
- Chimney outlet should be at least two feet above highest point of peaked roof.
- All unused chimney openings should be closed.
- Chimneys must conform to local, provincial or state codes, or in the absence of local regulations, to the requirements of the National Building Code.

Manufacturer recommends breech draft of -0.02 in. w.c.

Flue pipe must not pass through any floor or ceiling, may pass through a wall where suitable fire protection provisions have been installed.

- Canada, refer to CAN/CSA B-139 for rules governing the installation of oil burning equipment.
- United States, refer to NFPA 31 for regulations governing the installation of oil burning equipment.

See appendix A for burner set-up.

11. Barometric Damper Control

Barometric damper control, also known as draft regulator, is used on conventional chimney venting only. Control automatically maintains constant negative pressure. Ensures proper pressures are not exceeded. If chimney does not develop sufficient draft, draft control does not function properly.

- Install draft regulator in same room or enclosure as furnace. Draft regulator should not interfere with combustion air supplied to the burner.
- Locate control near furnace flue outlet.
- Install per instructions supplied with regulator.
- Set breech draft to -0.02 in. w.c.

12. Optional Direct Venting

Certain LRF/LRFV furnaces are manufactured as direct vent units. Refer to Direct Vent Supplement Installation, Operation and Maintenance Manual, part number 240011896, included with direct vent furnace, for details.

Direct venting requires use of specific oil burners, Beckett NX or Riello 40BF3 or 40BF5.

Refer to Appendix A, Tables A-2 and A-4.

13a. Fan Timer Board And Limit Control (LRF) [See Figure 2, page 15]

Electronic Fan Timer integrates control of burner and circulator fan operations. Control is central wiring point for most of furnace electrical components.

- United Technologies 1158-120 has an adjustable fan on time set by selecting dipswitch combination displayed in Chart 1. Fan on delay can be set at 30, 60, 90 or 120 seconds. Provides a delay between burner ignition and blower start-up to eliminate excessive flow of cold air when blower comes on. Manufacturer recommended fan on delay is 30 seconds for LRF100 models and 60 seconds for LRF65/80/90 models.
- United Technologies 1158-120 has an adjustable fan off time of 2, 3, 4 or 6 minutes as displayed in Chart 1. Fan off delay time starts when burner motor is de-energized at end of call for heat. Blower shutdown is delayed to remove any residual heat from heat exchanger. Manufacturer recommended fan off delay is 2 minutes.
- Electronic fan timer board works in conjunction with snap disc limit controls, performing a safety function, shutting off burner if furnace over-heats.

- Limit control is thermally operated and automatically resets. Limit control is factory installed, pre-set and is not adjustable.
- If limit control opens with United Technologies 1158-120 electronic fan control, circulating fan will energize. When limit closes, fan off timer begins. At the end of fan off time cycle burner is energized, initiating normal burner cycle.

Chart 1- United Technologies 1158-120 (LRF)

Dip Switch Position				Blower Delay Times	
1	2	3	4	On Seconds	Off Minutes
Off	Off			30	
On	Off			60	
Off	On			90	
On	On			120	
		Off	Off		2
		On	Off		3
		Off	On		4
		On	On		6

**13b. Fan Timer Board And Limit Control (LRFV)
[See Figure 3, page 14]**

United Technologies 1168-1 ECM tap board has adjustable fan on/off delay and airflow settings that must be adjusted in accordance with furnace input rating (nozzle size). Refer to Table A-10 for ECM blower set-up.

14. Electrical Connections

- Furnace is listed by Canadian Standards Association under NRTL (North American) Standard.
- All field wiring shall conform to CAN/CSA C22.1 Canadian Electrical Code, Part 1, and by local codes, where they prevail.
- United States, wiring shall conform to National Fire Protection Association NFPA-70, National Electrical Code, and with local codes and regulations.
- Wire furnace to separate dedicated circuit in main electrical panel.
- Suitably located circuit breaker can be used as service switch, separate service switch is advisable.
- Service switch is necessary if circuit breaker is close to the furnace, or furnace is located between circuit breaker and entry to furnace room.
- Clearly mark service switch. Install in accessible area between furnace and furnace room entry. Locate so as to reduce possibility it can be mistaken as light switch or similar device.
- Power requirement for all LRF models is: 120 VAC, 1 Ø, 60 Hz., 12A.
- Accessory equipment such as electronic air cleaners and humidifiers may be included on furnace circuit.

- Accessories requiring 120 VAC power sources such as electronic air cleaners and humidifier transformers may be powered from electronic fan timer board where provisions have been made for connections, but should have their own controls.
- Do not use direct drive motor connections as a power source, there is risk of damaging accessories.
- Thermostat wiring connections are shown in wiring diagrams in Appendix B. Some micro-electronic thermostats require additional controls and wiring. Refer to thermostat manufacturer's instructions.
- **ECM Blower note** - Single stage cooling use terminal Y/Y2. Two stage cooling use terminal Y1 for first stage and Y/Y2 for second stage. When Y1 is energized, air flow is reduced by 20%. Do not use terminal Y1 with single stage cooling or heat pump.
- Locate thermostat approximately 5 feet above floor, on inside wall, and where thermostat is exposed to average room temperatures. Avoid locations where thermostat is exposed to cold drafts, heat from nearby lamps and appliances, exposure to sunlight, heat from inside wall stacks, etc.
- Adjust thermostat heat anticipator to amperage draw of heating control circuit as measured at "R" and "W" terminals of thermostat. Do not measure current with thermostat connected to the circuit. Measure amperage by connecting ammeter between two wires which connect to thermostat "R" and "W" terminals.

15. Humidifier

- Humidifier is optional accessory available through most heating supplies outlets.
- Follow humidifier manufacturer's installation instructions
- Protect furnace heat exchanger from water or water droplets from humidifier.
- Do not use direct drive motor connections as source of power for 120 VAC humidifiers and humidifier transformers.

16. Piping Installation

- Install fuel system in accordance with requirements of CAN/CSA B-139, and local regulations.
- United States installation shall conform to NFPA No. 31 and local codes and authorities.
- Use only approved fuel oil tanks, piping, fittings and oil filter.
- Install oil filter as close to burner as possible.
- Refer to instructions and illustrations in oil burner and oil pump instructions shipped with the furnace.

17. Oil Filter

Install oil filter between fuel oil storage tank and oil burner. When using oil burner nozzle smaller than 0.65 U.S. Gallons Per Hour, install additional 7 to 10 micron filter as close as possible to oil burner.

18. Oil Burner Nozzles

Furnaces are certified for multiple firing rates. Furnace may be fired at ideal rate for wide range of structures by manipulating oil burner setup and blower settings. Refer to Table A-1 thru A-9, and furnace rating plate to determine proper combinations. Nozzles for alternate firing rates are included with furnace.

19. Oil Burner Adjustment

- Adjust burner air supply to maintain fuel to air ratio to obtain ideal combustion conditions.
- Lack of air causes "soft" and "sooty" flames, resulting in soot build-up throughout heat exchanger passages.
- Excess combustion air causes bright roaring fire and high stack temperatures resulting in poor fuel efficiency.
- LRF and LRFV operate most efficiently with No. 1 smoke spot on Bacharach Scale. Dust will eventually build up on air moving components of oil burner assembly resulting in decreased air supply with potential soot build up in flue gas passageways of heat exchanger. Soot behaves as insulator and impairs good heat transfer. Stack temperature increases, and efficiency decreases. To avoid this problem, adjust the air supply as follows:
 - » *Chimney vented units* - adjust air supply to provide no more than a trace smoke spot on the Bacharach scale.
 - » *Direct vented units* - adjust air supply for zero smoke per the Direct Vent Supplement Installation, Operation and Maintenance Manual included with direct vent furnace.

20. Burner Electrodes

Correct positioning of electrode tips with respect to each other, fuel oil nozzle, and burners is essential for smooth light ups and proper operation.

Refer to oil burner instructions provided with furnace and Appendix A Section A.2 in this manual for electrode specifications.

NOTICE

Do not tamper with furnace controls they are sensitive. If problems persist, call your service contractor.

21. Burner Primary (Safety) Control

Furnace is equipped with primary combustion control, also referred to as burner relay or burner protector relay, which uses a cad cell located in burner housing, to monitor and control combustion.

Dust or combustion residuals can build up on lens of cad cell impairing its response to flame. Check cad cell for cleanliness and proper alignment if primary control frequently shuts down combustion.

WARNING

Fire, burn, asphyxiation hazard. Do not start the burner unless blower access door is secured in place. Failure to follow these instructions could result in death or serious injury.

22a. CIRCULATING AIR BLOWER (LRF/LRFV)

- LRF furnace models may be equipped with either direct drive or belt drive blower systems.
- LRFV furnace models are equipped with direct drive blower systems.
- LRF models are equipped with PSC motors.
- LRFV models are equipped with electronically commutated motors (ECM).

Direct Drive Blower Systems

- Direct drive blower speed adjustments are not normally required in properly sized extended plenum duct systems. Motor RPM and air CFM delivery will vary automatically to accommodate conditions within usual range of external static pressures typical of residential duct systems.
- Under-sized duct systems may require higher blower speed to obtain system temperature rise.
- Some older duct systems were not designed to provide static pressure. They typically feature special reducing fittings at each branch run and lack block ends on the trunk ducts. These systems may require modification to provide some resistance to the airflow to prevent over-amping of direct drive blower motor. Selecting a lower blower speed may correct this problem.
- Direct drive blower speeds are adjusted by changing "hot" wires to motor winding connections. Refer to wiring diagrams in Appendix B or wiring diagram label affixed to furnace.
- **Do not move neutral wire (normally white wire) to adjust blower speed.**
- Single blower speed for both heating and cooling modes may be used. Use a "piggy-back connector" accommodating both wires on a single motor tap.
- It is also acceptable to connect selected motor speed with a pigtail joined to both heating and cooling speed wires with a wire nut.
- Safety precaution against accidental disconnection of wires by vibration, secure wire nut and wires with few wraps of electricians tape.
- **Do not connect power leads between motor speeds. Always connect neutral wire to motor's designated neutral terminal.**
- If joining blower speed wiring is done in furnace junction box, tape off both ends of unused wire.
- **Do not use blower speed wires as source of power to accessories as electronic air cleaners and humidifier transformers. Unused motor taps auto-generate sufficiently high voltages to damage accessory equipment.**

Belt Drive Blower Systems

WARNING

Improper installation could result in death or serious injury. Belt drive components operate at high speeds and may snag loose clothing resulting in injury or death. Have a trained service professional perform the following instructions. Failure to follow these instructions could result in death or serious injury.

Belt drive blower systems can be modified for speed and air delivery by adjusting variable speed motor pulley and changing blower pulley.

- Adjust variable speed motor pulley by loosening 5/32 Allen set screw in outer sheave. Turn outer sheave clockwise to increase blower speed, counter clockwise to reduce speed.
- Verify setscrew is tightened at one of the flat spots, failure to do so will convert the variable speed pulley to a fixed speed pulley by ruining the threads.
- Modify blower speed by changing the blower pulley. Smaller blower pulley will cause the blower to turn faster. Large pulley reduces blower speed.
- Large increases in the blower speed may increase power requirements.
- Check amperage draw of the blower motor after making changes. If amperage draw is greater than the value listed on the motor rating plate, replace with motor of higher horsepower.
- Deflection of 3/4 of an inch to 1 inch fan belt tension is necessary. Less deflection places a strain on the blower bearings and increases start up amperage draw.
- More deflection allows excess slippage and causes premature motor pulley wear.
- Automotive belt dressings are not recommended.
- Bar soap will work as belt dressing to reduce belt squeaks, etc. If using soap apply to the sides of belt only.

If operating belt drive blower at speeds above 1100 RPM, replace sintered bronze blower bearings with roller bearings.

WARNING

Electrical shock hazard. Turn OFF electrical power supply at service panel before opening blower access door. Failure to do so could result in death or serious injury.

22b. Circulating Air Blower (LRFV)

LRFV furnace models are equipped with electronically commutated motors (ECM).

Setting Blower Speed and "ON" and "OFF" Timings

Blower speed and on/off time delays are handled by ECM motor programming and are set via dipswitches per Table A-10. Heating airflow rate is SW1 and on/off delay is SW4, both are set according to firing rate. Cooling airflow rate is SW2 and if used is set according to installed cooling capacity. SW3 can be used to adjust airflow rate by (+) or (-) 15%. Features of this ECM variable speed motor are that it will deliver a constant airflow within a wide range of external static pressures, and also includes:

- **Soft Start:** ECM will slowly ramp up to required operating speed. In heating cycle allows heat exchanger to reach operating temperature before set heat speed, minimizes noise and increases comfort.
- **Soft Stop:** At end of heating cycle, ECM will slowly ramp down. Allows increased energy efficiency and reduced noise levels.
- **Dehumidification:** Feature is programmed into the variable speed motor. At start of each cooling cycle, variable speed motor will run at 82% of rated airflow for 7.5 minutes. After 7.5 minutes has elapsed, motor will increase to 100% of rated airflow. Used to provide dehumidification and improve system efficiency.
- **Continuous Fan Operation:** When thermostat continuous fan (G) switch is on without call for heating or cooling, indoor fan is immediately energized at 50% of cooling speed. Allows continuous circulation of air between calls for heating or cooling. If call for heat (W) or cool (Y) occurs during continuous fan, blower remains energized.

23. Maintenance And Service

Routine Maintenance By Home Owner

- Arrange for professional servicing of furnace by the service or installation contractor annually.
- Homeowner is to maintain air filter or filters. A dirty filter can cause furnace to over-heat, fail to maintain indoor temperature during cold weather, increase fuel consumption and cause component failure.
- Inspect, clean or replace filter monthly.
- Furnace is supplied with semi-permanent type filter. If filter is damaged, replace with filters of same size and type.
- During monthly filter inspection, inspect general condition of furnace. Watch for signs of oil leaks in vicinity of oil burner, soot forming on any external part of furnace, soot forming around joints in vent pipe, etc. If any of these conditions are present, please advise your service or installation contractor.

Annual Service By Contractor

- Inspect heat exchanger periodically and clean if necessary.

WARNING

Electrical shock hazard. Turn OFF electrical power supply at service panel before service or maintenance. Failure to do so could result in death or serious injury.

- If cleaning is necessary, shut off oil supply, shut off power to the furnace and remove burner.
- Remove cleanout cover and turbulators.
- Wire brush can be used to loosen dirt and debris on the inside surfaces of heat exchanger. Clean out all accumulated dirt, soot and debris with a wire handled brush and industrial vacuum cleaner.
- Clean and reinstall turbulators.
- Before replacing cleanout cover, inspect gaskets. If gasket is broken, remove remnants and replace with new gaskets. Replace cleanout cover.
- Blower motor is factory oiled and permanently sealed. Do not lubricate. Excess oil causes premature electric motor failure.
- Inspect blower fan. Clean if necessary.
- Oil Burner Maintenance: Follow oil burner manufacturer instructions.
- Change oil burner nozzle and oil filter annually.
- Clean and inspect venting system for signs of deterioration and leakage. Replace pitted or perforated vent pipe and fittings.
- Barometric damper should open and close freely.
- Check electrical connections to ensure tight connections. Safety controls such as the high limit controls should be tested for functionality.
- Check fan control to ensure fan on and off delay function continues to start and stop blower fan at optimal settings.
- Check operation of limit switch.

24. Operating Instructions (LRF)

Before Lighting

1. Open all supply and return air registers and grilles.

WARNING

Fire, burn, explosion, asphyxiation hazard.

- Do not start burner when excess oil has accumulated, furnace is full of vapor, or combustion chamber is very hot.
- Do not burn garbage or paper in furnace.
- Do not leave paper or rags around furnace.

Failure to follow these instructions could result in death or serious injury.

2. Open all valves in oil pipes.
3. Turn on electric power supply

To Light Unit

1. Set thermostat above room temperature to call for heat. Burner should start. It may be necessary to press RESET button on primary combustion control relay.

2. There is a fan on time delay before circulating fan is energized. United Technologies 1158-120 has adjustable fan on time set by selecting dipswitch combination displayed in Chart 1. Fan on delay can be set at 30, 60, 90 or 120 seconds. Manufacturer recommended fan on delay is 30 seconds for LRF100 models and 60 seconds for LRF65/80/90 models.
3. Set thermostat below room temperature. Oil burner stops.
4. Air circulation blower continues to operate until time off setting selected on electronic fan timer control times out. United Technologies 1158-120 has adjustable fan off time of 2, 3, 4 or 6 minutes. Manufacturer recommended fan off delay is 2 minutes for all models. Fan timer control adjustments may be altered if air at room registers is high upon blower start up or shutdown.
5. Restore thermostat setting to comfortable temperature.

NOTICE

If furnace is to be shut down for extended period of time, close oil supply valve to burner.

To Shut Down Unit

1. Set thermostat to lowest possible setting.
2. Set manual switch (if installed) in electrical power supply line to "OFF".

25. Operating Instructions (LRFV)

Before Lighting

1. Open all supply and return air registers and grilles.
2. Open all valves in oil pipes.
3. Turn on electric power supply.

To Light Unit

1. Set thermostat above room temperature to call for heat. Burner should start. It may be necessary to press RESET button on primary combustion control relay.
2. There is a fan on time delay before circulating fan is energized. United Technologies 1168-1 has adjustable fan on/off time delay programmed into ECM motor, and is set by selecting SW4 DIP switch combination displayed in Table A-10. Adjust Fan on/off delay according to input (nozzle size).
3. Set thermostat below room temperature. Oil burner stops.
4. Air circulation blower continues to operate until blower off delay setting programmed into ECM motor times out.

NOTICE

If furnace is to be shut down for extended period of time, close oil supply valve to burner.

To Shut Down Unit

1. Set thermostat to lowest possible setting.
2. Set manual switch (if installed) in electrical power supply line to "OFF".

APPENDIX A - CHECK OUT AND ADJUSTMENTS

Check out and adjustments

LRF and LRFV furnaces may be used with following oil burners.

Beckett AFG and Riello 40F3 and Carlin EZ-LF oil burners are for chimney vent applications using indoor air for combustion only.

Beckett NX and Riello 40BF3/40BF5 oil burners are for direct vent applications using outdoor air for combustion only.

Settings shown below are for initial startup only. Final adjustments shall be made using combustion test instructions.

Table A-1 Beckett AFG Oil Burner Set-Up

Beckett AFG Series Oil Burners (For use with chimney vented units only)							
Furnace Model	Output BTU/Hr	Burner Model	Delavan Nozzle	Pump Pressure [PSIG]	Flow Rate [USGPH]	Head	Air Setting
LRF65 LRFV65	66,000	AFG70MPSS	0.50 / 45°W	140	0.55	L2	4
LRF80 LRFV80	78,000	AFG70MPSS	0.50 / 45°W	175	0.65	L2	5
LRF90 LRFV90	89,000	AFG70MPSS	0.60 / 60°W	175	0.75	L2	7
LRF100 LRFV100	100,000	AFG70MPSS	0.65 / 60°W	175	0.85	L2	8

Table A-2 Beckett NX Oil Burner Setup

Beckett NX Series Oil Burners (For use with direct vent units using outdoor combustion air only)							
Furnace Model	Output BTU/Hr	Burner Model	Delavan Nozzle	Pump Pressure [PSIG]	Flow Rate [USGPH]	Low Firing Rate Baffle	Air Setting
LRF65NXU LRFV65NXU	65,000	NX56LQ	0.50 / 60°W	140	0.55	Yes	3
LRF80NXU LRFV80NXU	76,000	NX56LQ	0.50 / 60°W	175	0.65	Yes	3.25
LRF90NXU LRFV90NXU	87,000	NX56LQ	0.60 / 60°W	175	0.75	No*	3.25
LRF100NXU LRFV100NXU	98,000	NX56LQ	0.65 / 60°W	175	0.85	No*	3.75

* Burner is factory equipped with low firing rate baffle. Remove for 0.75 and 0.85 USGPH firing rates.

Table A-3 Riello 40F3 Burner Set-Up

Riello 40F3 Series Oil Burners (For use with chimney vented units only)							
Furnace Model	Output BTU/Hr	Burner Model	Delavan Nozzle	Pump Pressure [PSIG]	Flow Rate [USGPH]	Head Setting	Air Setting
LRF65RF LRFV65RF	66,000	40F3 VSBT	0.50 / 90°B	125	0.55	0	1.6
LRF80RF LRFV80RF	77,000	40F3 VSBT	0.55 / 80°B	140	0.65	0	2.1
LRF90RF LRFV90RF	88,000	40F3 VSBT	0.65 / 80°B	133	0.75	1	2.5
LRF100RF LRFV100RF	99,000	40F3 VSBT	0.75 / 80°B	128	0.85	2	3

Table A-4 Riello 40BF Burner Set-Up

Riello 40BF3/40BF5 Series Oil Burners (For use with direct vent units using outdoor combustion air only)							
Furnace Model	Output BTU/Hr	Burner Model	Delavan Nozzle	Pump Pressure [PSIG]	Flow Rate [USGPH]	Turbulator Setting	Air Setting
LRF65RBU LRFV65RBU	65,000	40BF3	0.50 / 90°B	125	0.55	0.0	4.25
LRF80RBU LRFV80RBU	76,000	40BF3	0.55 / 80°B	140	0.65	1.0	5.25
LRF90RBU LRFV90RBU	87,000	40BF5	0.65 / 80°B	140	0.75	0.0	3.75
LRF100RBU LRFV100RBU	98,000	40BF5	0.75 / 80°B	130	0.85	0.0	4.25

Note: Riello 40BF3 burner is required for 0.55 and 0.65 USGPH firing rates. Riello 40BF5 burner is required for 0.75 and 0.85 USGPH firing rates.

Table A-5 Carlin EZ-LF Oil Burner Set-Up

Carlin EZ-LF Series Oil Burners (For use with chimney vented units only)								
Furnace Model	Output BTU/Hr	Burner Model	Delavan Nozzle	Pump Pressure [PSIG]	Flow Rate [USGPH]	Air Band	Head Bar	Air Setting
LRF65C LRFV65C	66,000	EZ-LF	0.50 / 70°B	125	0.55	Single Slot	0.60 / 0.65	35%
LRF80C LRFV80C	78,000	EZ-LF	0.50 / 70°B	170	0.65	Single Slot	0.60 / 0.65	65%
LRF90C LRFV90C	89,000	EZ-LF	0.65 / 70°B	135	0.75	Two Slot*	0.75	45%
LRF100C LRFV100C	100,000	EZ-LF	0.65 / 70°B	170	0.85	Two Slot*	0.85 / 1.00	45%

* Burner is factory equipped with single slot air band. Replace with furnished two slot air band for 0.75 and 0.85 USGPH firing rates.

A.1 Oil Burner Air Adjustment

Consult oil burner instructions provided in furnace documents envelope for specific information concerning burner adjustments, operation and troubleshooting.

Beckett AFG Burner (Chimney Vent)

Adjust air band by loosening locking screw. Re-tighten locking screw after each adjustment. Locking screw must be tight when taking combustion readings, as airflow changes when screw is loosened.

Beckett NX Burner (Direct Vent)

Loosen splined nut on nozzle line one turn. Turn adjustment screw clockwise to increase air and counter clockwise to decrease air. Tighten splined nut after obtaining proper setting.

Riello 40F3 Burner (Chimney Vent)

Combustion air is adjusted by removing burner cover. Loosen screws that secure air adjustment plate. Move adjusting plate to either increase or decrease combustion air. When proper air setting is achieved, re-tighten fixing screws. Re-install cover.

Riello 40BF Burner (Direct Vent)

Combustion air can be adjusted with burner cover on. Remove plastic cover on top right hand side of burner cover. With Phillips screwdriver turn adjusting screw clockwise to increase air and counter clockwise to decrease air. When combustion air is set, reinsert plastic cover.

Carlin EZ-LF (Chimney Vent)

Adjust air band by loosening locking screw. Re-tighten locking screw after adjustment.

A.2 Burner Electrodes

Adjustment of electrode tips with respect to each other, nozzle, burner head is very important to ensure smooth start-ups and to permit efficient combustion.

Beckett AFG

- Electrode gap: 5/32 inch.
- Distance above horizontal center-line: 1/4 inch.
- Distance ahead of nozzle: 1/8 inch.
- "Z" dimension, distance from front of end cone (head) to face of nozzle should be 1-3/4 inch.

Beckett NX

- Electrode gap: 5/32 inch.
- Distance above horizontal center-line: 1/4 inch.
- Distance ahead of nozzle: 3/32 inch.
- Check/adjust zero calibration per Beckett NX oil burner manual supplied with furnace.

Riello Burners

- Electrode gap: 5/32 inch.
- Distance above horizontal center-line: 13/64 inch.
- Distance ahead of nozzle: 5/64 to 7/64 inch.

Carlin Burners

- Electrode gap: 1/8 inch to 5/32 inch.
- Distance above horizontal center-line: 5/16 inch.
- Distance ahead of nozzle: Flush to 1/16 inch.

A.3 Start Up

Use following instructions to set the burner:

1. Shut off electrical power to the furnace.
2. Install oil pressure gauge to pressure port on oil pump. (Refer to oil pump specification sheet included with burner instructions).
3. Restore electrical power to furnace.
4. Start furnace and bleed all air from fuel oil lines.
5. Close purge valve and fire the unit.
6. Allow furnace to warm up to normal operating temperatures. During this time, set pump pressure in accordance with data provided in Appendix A, Table A-1 thru A-3.
7. **Chimney vented units** - Drill 1/4" test port in venting between furnace flue outlet and draft regulator (barometric damper) to take smoke readings.
8. **Direct vented units** - Do not drill. Use test port in furnished appliance connector to take smoke readings.
9. When furnace has reached "steady state" (after approximately 10 minutes), set combustion air damper to get TRACE of smoke for chimney vented units.
10. Check system temperature rise. *Temperature rise is the difference between return air temperature measured at a point near return air inlet, and supply air temperature measured near furnace outlet.*

System temperature rise is listed on furnace rating plate. If temperature rise is too high, airflow must be increased. If temperature rise is too low, slow fan down.
11. **Chimney vented units** - after air adjustments have been completed, recheck the breech draft. Breech draft should be adjusted to -0.02 inches w.c.
12. Turn burner off. Observe duct thermometer in supply air stream, note temperature blower fan stops. Fan adjustments can be made by moving dipswitch settings on timer control board for fan off delay.
13. Check operation of limit switch.
 - A. Shut off power to furnace.
 - B. Temporarily remove neutral wire from PSC blower motor or from neutral terminal on fan timer control, or remove 5 pin power connector from ECM blower motor. Isolate AC line voltage pins on 5 pin power connector with electrical tape to prevent electric shock hazard.
 - C. Restore electrical power to furnace.
 - D. Set thermostat above room temperature.
 - E. After two or three minutes of burner operation, limit control should turn burner off.
 - F. When limit function test is complete, shut off electrical power to furnace, replace neutral wire or 5 pin power connector. Restore power.
 - G. Blower fan will start up immediately. Once temperature has dropped and limit control has reset, fan will operate until fan off time is reached.
 - H. Oil burner will resume operation and continue until thermostat is satisfied.
 - I. Restore thermostat setting to comfortable temperature.

14. Set heat anticipator adjustment in thermostat (if so equipped), by removing "R" or "W" wire to thermostat. Read amperage draw between the two wires. Failure to remove one of the wires from thermostat while performing this test could burn out heat anticipator. Set heat anticipator to amperage measured.
15. **Direct vented units** - Check all joints in positive pressure venting system for leaks before leaving site.
16. Run furnace through at least three full cycles before leaving installation, to ensure all controls are operating properly.

A.4 Final Check Out

Verify all safety devices and electrical components have been set for normal operation.

Verify all electrical connections are tight and wiring is secure.

Verify homeowner is informed and understands:

- Where circuit breaker or fuse is located in main electrical panel.
- Where furnace switch is located, and switch "on" and "off" positions if not obvious.
- Where oil shut-off valve from oil storage tank is located.
- Thermostat operation, and other related accessories.
- How to operate manual reset button on primary control, and when not to push the reset button.
- How and where to visually inspect venting system for leaks or other problems.
- How to inspect, clean and replace air filter, and other homeowner maintenance procedures.
- Who to call for emergency service and routine annual service.

FIGURE 2: UNITED TECHNOLOGIES 1158-120 FAN TIMER BOARD (LRF)

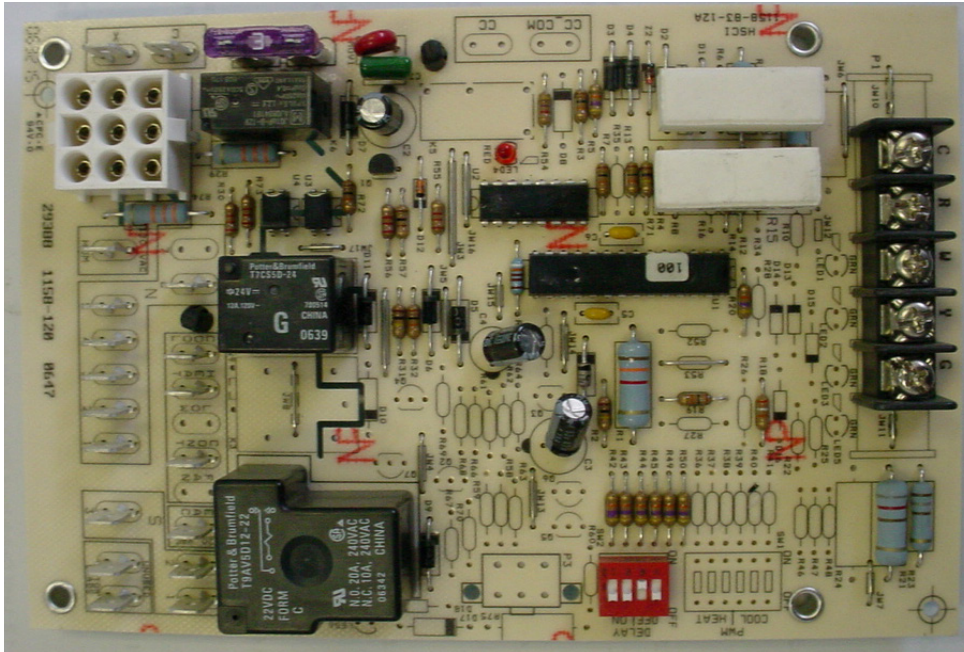
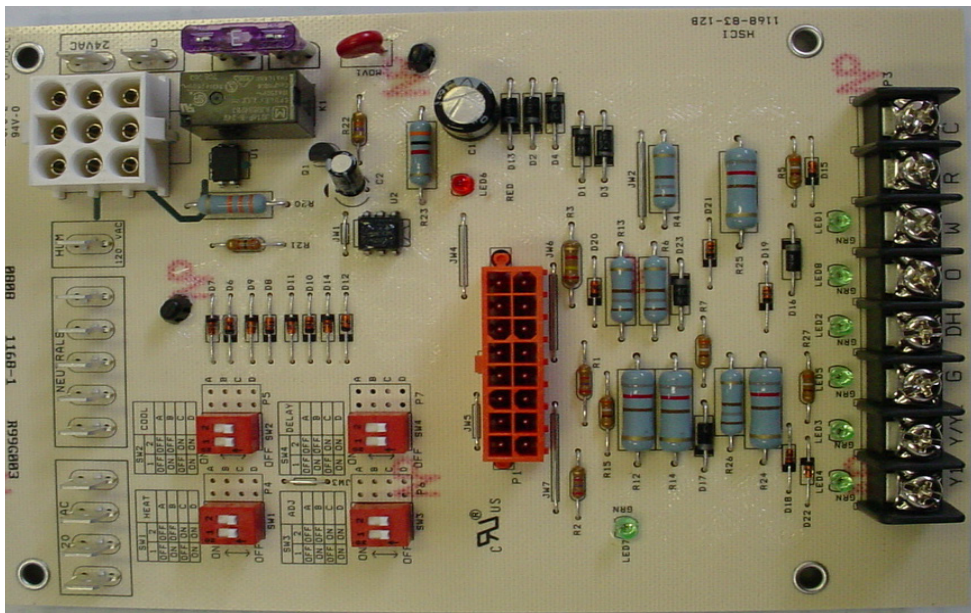

FIGURE 3: UNITED TECHNOLOGIES 1168-1 ECM TAP BOARD (LRFV)



A.5 Blower Setup

Table A-6 Direct Drive Blower Motor Setup - 1/2 HP PSC 4 Speed Motor

Furnace Model	Blower	Heating Blower Set-Up		Cooling Capacity	
		0.20 in. w.c.	0.50 in. w.c.	Tons	CFM Range @ 0.5 in. w.c.
		Speed	Speed		
LRF65	100-10T DD	Low	Low	3	766-1249
LRF80	100-10T DD	Low	Medium Low	3	766-1249
LRF90	100-10T DD	Medium Low	Medium High	3	766-1249
LRF100	100-10T DD	Medium High	High	3	766-1249

Table A-7 Direct Drive Blower Characteristics - 1/2 HP PSC 4 Speed Motor

Furnace Model	Blower	Motor FLA	ΔT	Speed	CFM				
					External Static Pressure – Inches w.c.				
					0.20	0.30	0.40	0.50	0.60
LRF 65 – 100	100-10T DD	6.0	55-85 °F	High	1455	1383	1314	1249	1160
				Med-High	1427	1345	1286	1216	1128
				Med-Low	1234	1170	1135	1054	973
				Low	827	819	805	766	709

Table A-8 Belt Drive Blower Motor Setup - 1/2 HP PSC Single Speed Motor

Furnace Model	Blower	Heating Blower Set-Up			Cooling Capacity	
		0.20 in. w.c.			0.2 in. w.c.	
		Motor	Blower	Belt	Tons	CFM Range
LRF65	100-10T	3-1/4" X 1/2" 3 T.O.	6" X 3/4"	4L370	2.5-3.0	960-1300
LRF80	100-10T	3-1/4" X 1/2" 2 T.O.				
LRF90	100-10T	3-1/4" X 1/2" 1 T.O.				
LRF100	100-10T	3-1/4" X 1/2" 0 T.O.				

Table A-9 Belt Direct Drive Blower Characteristics - 1/2 HP PSC Single Speed Motor

Furnace Model	Motor FLA	ΔT	Blower	Motor Pulley Turns Out	CFM				
					External Static Pressure – Inches w.c.				
					0.1	0.2	0.3	0.4	0.5
LRF65	7.9	55-85 °F	100-10T	0	1400	1300	1183	1052	904
LRF80				1	1307	1190	1061	915	752
LRF90				2	1217	1076	927	744	544
LRF100				3	1110	960	793	536	248

TIP

Formulas will assist with design of duct-work and determination of air flow delivery.

CFM = Bonnet Output / (1.085 x System Temperature Rise (ΔT))

System Temperature Rise (ΔT) = Bonnet Output / (1.085 x CFM)

APPENDIX A - CHECK OUT AND ADJUSTMENTS

Table A-10 Direct Drive Blower Motor Setup - 1/2 HP ECM Variable Speed Constant CFM Motor

Dip Switch Adjustment Chart

For Input 0.55 USGPH TO 0.85 USGPH

SW1 - HEAT		POS.	INPUT USGPH
DIP Switch Position			
1	2		
OFF	OFF	A	0.65
ON	OFF	B	0.85
OFF	ON	C	0.75
ON	ON	D	0.55

SW2 - COOL		POS.	AC Size (TON)
DIP Switch Position			
1	2		
OFF	OFF	A	3.5
ON	OFF	B	3.0
OFF	ON	C	2.5
ON	ON	D	2.0

SW3 - ADJUST		POS.	CFM
DIP Switch Position			
1	2		
OFF	OFF	A	0%
ON	OFF	B	(+)15%
OFF	ON	C	(-)15%
ON	ON	D	N/A

SW4 - DELAY		POS.	INPUT USGPH
DIP Switch Position			
1	2		
OFF	OFF	A	0.65
ON	OFF	B	0.85
OFF	ON	C	0.75
ON	ON	D	0.55

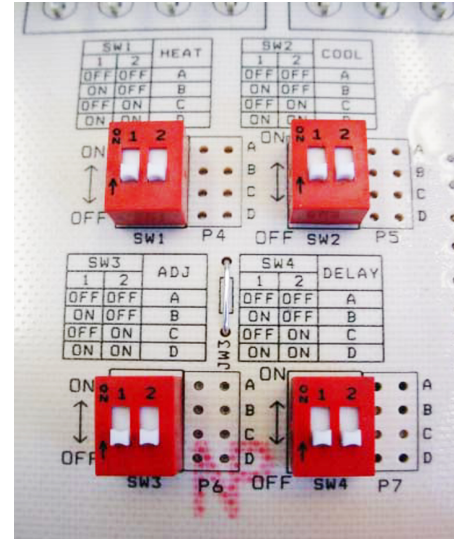

NOTE:

SW1 (HEAT) AND SW4 (DELAY) DIP SWITCHES MUST BOTH BE ADJUSTED ACCORDING TO INPUT (FIRING RATE).

SW2 (COOL): 1 TON is approximately equal to 400 CFM

SW3 (ADJUST) Increase OR decrease CFM respectively

Table A-11 Direct Drive Blower Characteristics - 1/2 HP ECM Variable Speed Constant CFM Motor

Furnace Model	Blower	Motor HP	Motor FLA	ΔT
LRFV 65 - 100	100-10T DD	1/2 HP ECM	7.7	55-85 °F

OIL HEATING				
SW1 HEAT DIP SWITCH POSITION	INPUT [USGPH]	CFM WITH SW3-ADJ DIP SWITCH POSITION A	CFM WITH SW3-ADJ DIP SWITCH POSITION B	CFM WITH SW3-ADJ DIP SWITCH POSITION C
A (1=OFF, 2=OFF)	0.65	1016	1168	864
B (1=ON, 2=OFF)	0.85	1430	1600	1216
C (1=OFF, 2=ON)	0.75	1229	1413	1045
D (1=ON, 2=ON)	0.55	828	952	704

CONTINUOUS FAN				
SW2 COOL DIP SWITCH POSITION	AC SIZE [TONS]	CFM WITH SW3-ADJ DIP SWITCH POSITION A	CFM WITH SW3-ADJ DIP SWITCH POSITION B	CFM WITH SW3-ADJ DIP SWITCH POSITION C
A (1=OFF, 2=OFF)	3.5	700	805	595
B (1=ON, 2=OFF)	3.0	600	690	510
C (1=OFF, 2=ON)	2.5	500	575	425
D (1=ON, 2=ON)	2.0	400	460	340

APPENDIX A - CHECK OUT AND ADJUSTMENTS

Table A-11 Direct Drive Blower Characteristics - 1/2 HP ECM Variable Speed Constant CFM Motor - continued

COOLING OR HEAT PUMP HEATING				
SW2 COOL DIP SWITCH POSITION	AC SIZE [TONS]	CFM WITH SW3-ADJ DIP SWITCH POSITION A	CFM WITH SW3-ADJ DIP SWITCH POSITION B	CFM WITH SW3-ADJ DIP SWITCH POSITION C
A (1=OFF, 2=OFF)	3.5	1400	1600	1190
B (1=ON, 2=OFF)	3.0	1200	1380	1020
C (1=OFF, 2=ON)	2.5	1000	1150	850
D (1=ON, 2=ON)	2.0	800	920	680

The CFM's shown are reduced by 20% if 24 VAC input is to Y1 (slow speed of 2 speed compressor) instead of Y/Y2

DELAY PROFILE FOR OIL HEATING				
SW4 DELAY DIP SWITCH POSITION	INPUT [USGPH]	PRE RUN ON DELAY TIME - CFM LEVEL	SHORT RUN ON DELAY TIME - CFM LEVEL	OFF DELAY TIME - CFM LEVEL
A (1=OFF, 2=OFF)	0.65	60 SECONDS - 0%	60 SECONDS - 63%	2 MINUTES - 75%
B (1=ON, 2=OFF)	0.85	30 SECONDS - 0%	60 SECONDS - 63%	2 MINUTES - 88%
C (1=OFF, 2=ON)	0.75	60 SECONDS - 0%	60 SECONDS - 88%	2 MINUTES - 82%
D (1=ON, 2=ON)	0.55	60 SECONDS - 0%	60 SECONDS - 50 %	2 MINUTES - 69%

DELAY PROFILE FOR COOLING OR HEAT PUMP HEATING				
NO ADJUSTMENT REQUIRED	AC SIZE [TONS]	PRE RUN ON DELAY TIME - CFM LEVEL	SHORT RUN ON DELAY TIME - CFM LEVEL	OFF DELAY TIME - CFM LEVEL
N/A	ALL	7.5 MINUTES - 82%	NONE	NONE

Chimney Vent Furnace Wiring Diagram LRF/LRFV

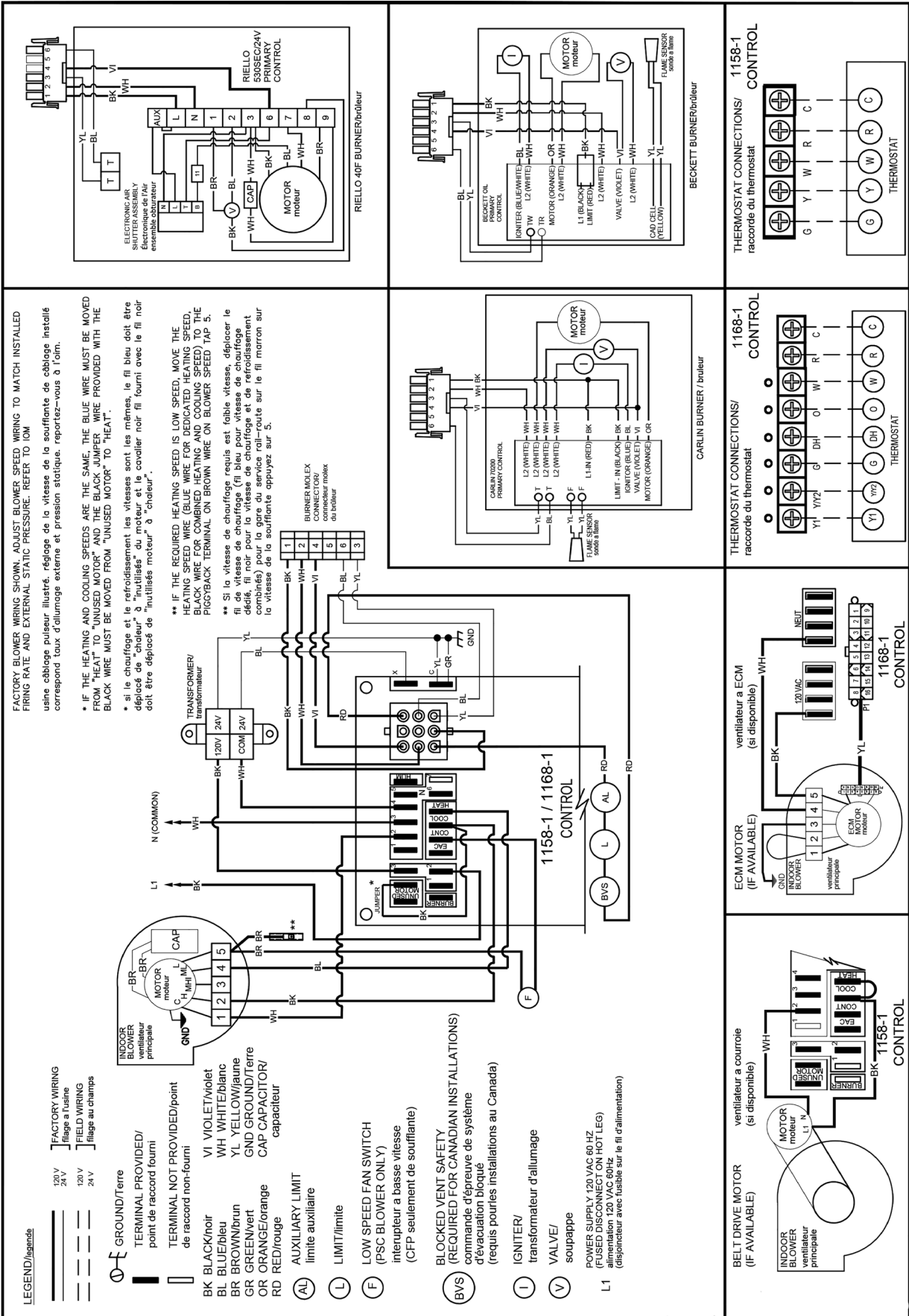

Direct Vent Furnace Wiring Diagram LRF/LRFV

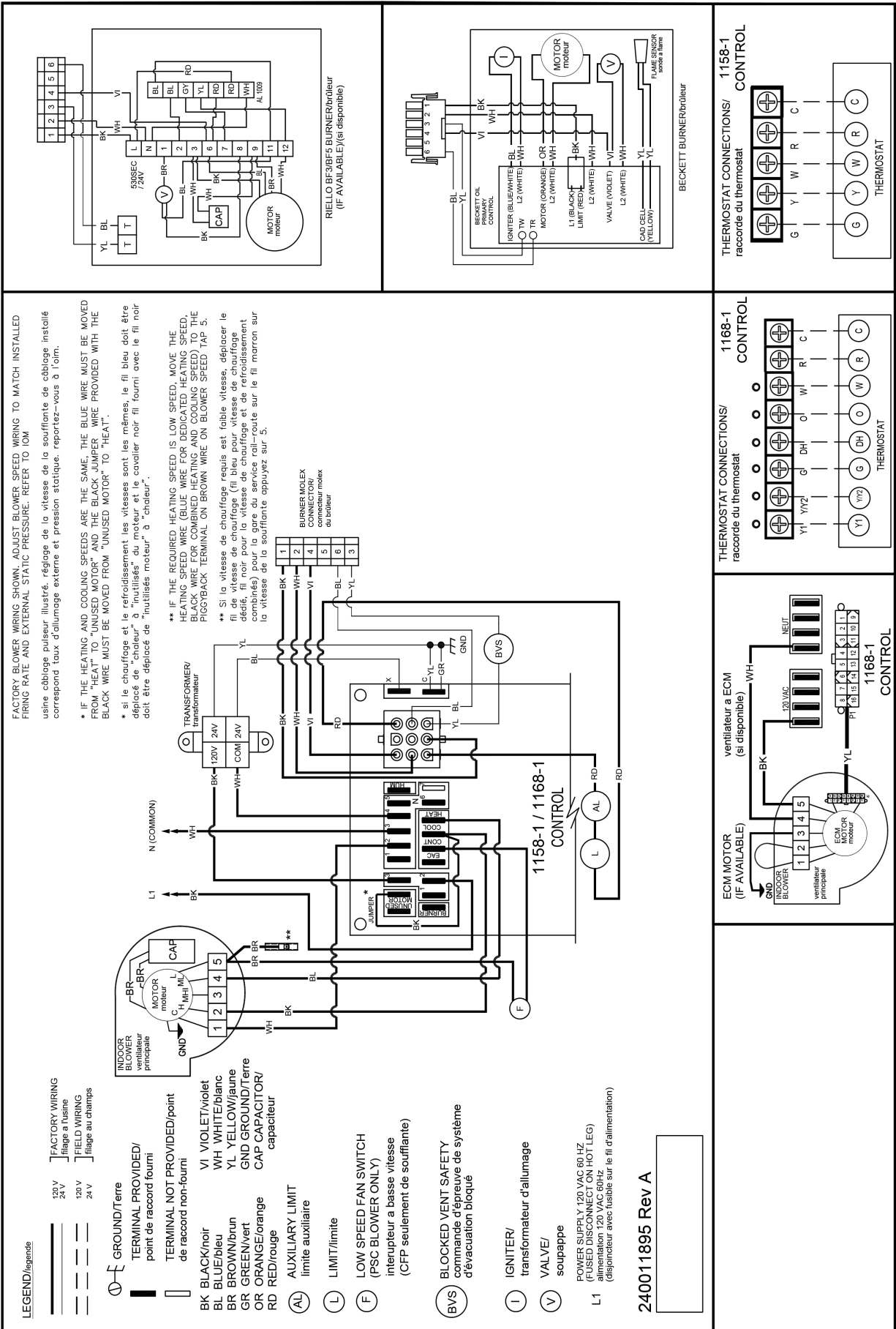

FACTORY BLOWER WIRING SHOWN. ADJUST BLOWER SPEED WIRING TO MATCH INSTALLED FIRM RATE AND EXTERNAL STATIC PRESSURE. REFER TO IOM

usine câblage pulseur illustré. réglage de la vitesse de la soufflante de câblage installé correspond taux d'allumage externe et pression statique. reportez-vous à l'iom.

* IF THE HEATING AND COOLING SPEEDS ARE THE SAME, THE BLUE WIRE MUST BE MOVED FROM "HEAT" TO "UNUSED MOTOR" AND THE BLACK JUMPER WIRE PROVIDED WITH THE BLACK WIRE MUST BE MOVED FROM "UNUSED MOTOR" TO "HEAT".

* si le chauffage et le refroidissement les vitesses sont les mêmes, le fil bleu doit être déplacé de "chauffeur" à "inutilisés" du moteur et le cavalier noir fil fourni avec le fil noir doit être déplacé de "inutilisés" du moteur à "chauffeur".

** IF THE REQUIRED HEATING SPEED IS LOW SPEED, MOVE THE HEATING WIRE (BLUE WIRE FOR DEDICATED HEATING SPEED, BLACK WIRE FOR COMBINED HEATING AND COOLING SPEED) TO THE PIGTBACK TERMINAL ON BROWN WIRE ON BLOWER SPEED TAP 5.

** Si la vitesse de chauffage requis est faible vitesse, déplacer le fil de vitesse de chauffage (fil bleu pour vitesse de chauffage dédié, fil noir pour la vitesse de chauffage et de refroidissement combinés) pour la gare du service rail-route sur le fil marron sur la vitesse de la soufflante appuyez sur 5.

LEGEND/Légende

120 V
24 V

FACTORY WIRING
filage à l'usine

120 V
24 V

FIELD WIRING
filage au champs

GROUND/Terre

TERMINAL PROVIDED/point de raccord fourni

TERMINAL NOT PROVIDED/point de raccord non-fourni

BK BLACK/noir

BL BLUE/bleu

BR BROWN/brun

GR GREEN/vert

OR ORANGE/orange

RD RED/rouge

AUXILIARY LIMIT
limite auxiliaire

L LIMIT/limite

F LOW SPEED FAN SWITCH
(PSC BLOWER ONLY)
interrupteur à basse vitesse
(CFF seulement de soufflante)

BVS BLOCKED VENT SAFETY
commande d'épreuve de système
d'évacuation bloqué

I IGNITER/
transformateur d'allumage

V VALVE/
soupape

POWER SUPPLY 120 VAC 60 HZ
(FUSED DISCONNECT ON HOT LEG)
alimentation 120 VAC 60 HZ
(disjoncteur avec fusible sur le fil d'alimentation)

240011895 Rev A

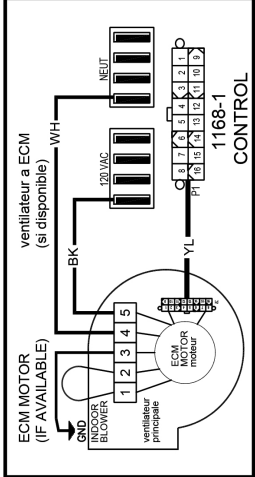
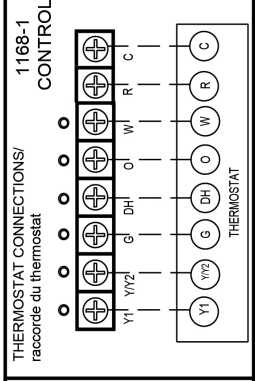
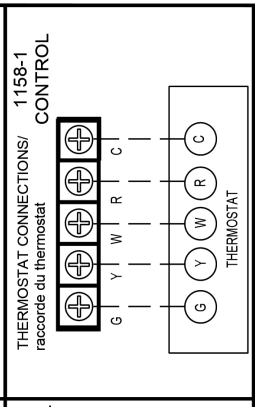
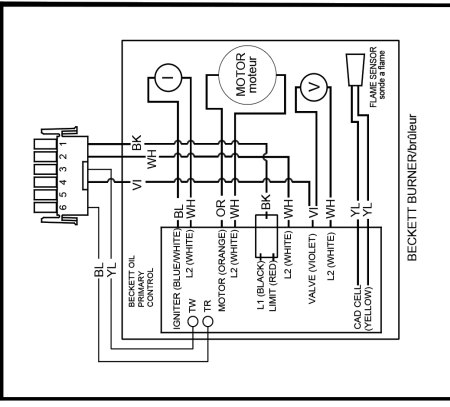
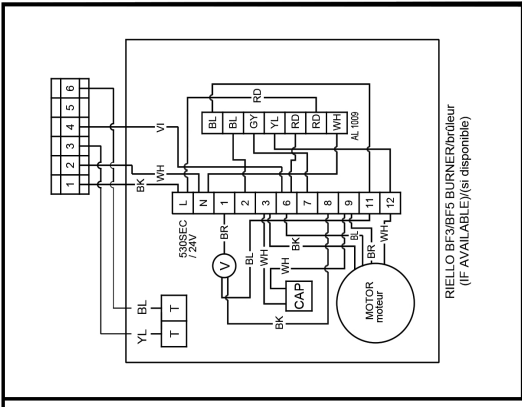

APPENDIX C - SEQUENCE OF OPERATION AND TROUBLESHOOTING

Table C-1: 1158-120 Electronic Fan Timer Board (EFT) Detailed Sequence Of Operation (LRF)

Mode	Action	System Response
HEAT	Thermostat calls for heat. ("W" terminal is energized).	EFT closes the oil primary control T - T connections. Ignition system and the oil primary control start the furnace. Oil flows as long as the oil primary control senses flame. Burner motor is energized and heat "fan on" delay timing begins. When timing is complete, the circulator fan is energized at heat speed.
	Thermostat ends call for heat. ("W" terminal is de-energized).	The oil primary control is de-energized, terminating the burner cycle. Heat "fan off" delay timing begins. Length of delay depends on EFT dipswitch settings. When timing is complete, the circulator fan is de-energized. EFT returns to standby mode, (Oil primary control and circulator fan are off, unless continuous fan operation is selected at the thermostat).
	Burner fails to light.	Oil primary control locks out within lockout timing, (15 seconds). Burner motor is de-energized. (Even though thermostat is still calling for heat). If circulator fan has started, it continues through the selected heat "fan off" delay period.
	Established flame fails.	Burner motor is de-energized and oil primary control goes into recycle mode. If the selected heat "fan off" delay timing is longer than the recycle delay timing, the circulator fan continues to run through the next trial for ignition.
COOL	Thermostat begins call for cool. (G and Y terminals are energized).	Cooling contactor is energized immediately. Circulator fan is energized at cool speed.
	Thermostat ends call for cool. (G and Y terminals are de-energized).	Cooling contactor is de-energized immediately. Circulator fan turns off immediately.
FAN	Thermostat begins call for fan. (G terminal is energized).	Circulator fan is energized immediately at cooling speed.
	Thermostat ends call for fan. (G terminal is de-energized).	Circulator fan is de-energized immediately.
LIMIT	Limit switch string opens.	Oil primary control shuts off burner. Circulator fan is energized immediately at heat speed. EFT opens the oil primary control T - T connections. Circulating fan runs as long as limit string stays open. If there is a call for cooling or fan, the circulating fan switches from heating to cooling speed.
	Limit switch string closes (with existing call for heat).	EFT begins heat "fan off" delay sequence. Circulating fan turns off after the selected heat "fan off" timing. EFT re-closes the oil primary control T - T connections. Oil primary control is energized, initiating burner light off.
	Limit switch string closes (without existing call for heat).	Circulator fan turns off when heat "fan off" delay time is complete. Normal operation resumes; EFT control is in standby mode awaiting next thermostat command.
FAN	Continuous circulating fan is connected.	Circulating fan is energized when there is no call for heat, cool, or fan. If fan operation is required by a call for heat, cool, or fan, the EFT switches off the continuous fan speed tap before energizing the other fan speed.
EAC	Electronic Air Cleaner is connected.	Electronic air cleaner (EAC) connections are energized when the heat or cool speed of the circulator fan is energized. EAC connections are not energized when the optional continuous fan terminal is energized.
HUM	Humidity control is connected.	Humidifier connections are energized when the oil burner motor is energized.

Table C-2: 1168-1 ECM Tap Board Sequence of Operation (LRFV)

Thermostat Input LEDs (LED 1-5, LED 8)

Six green LEDs are placed behind their respective thermostat connections (Y1, Y/Y2, G, DH, O, W) and illuminate whenever a call is present.

Mode	Action	System Response
HEAT	Thermostat call for heat "W"	The 24 VAC input signal is passed to pin 2 of P1 and will drive the K1 relay that provides dedicated contacts to the T-T input of the oil primary control. Blower runs on heating speed profile.
COOL	Thermostat calls for single stage cooling or second stage of two stage cooling "Y/Y2"	The 24 VAC input signal is passed to pin 14 of P1. Blower runs on cooling speed profile.
	Thermostat calls for first stage of two stage cooling "Y1" while "Y/Y2" is not calling	The 24 VAC input signal is passed to pin 6 of P1. Blower runs at 80% of cooling speed profile.
FAN	Thermostat calls for fan "G"	The 24 VAC input signal is passed to pin 15 of P1. Blower runs at continuous low speed profile which is 50% of cooling speed.
DEHUMID	Thermostat calls for Dehumidification "DH"	The 24 VAC input signal is passed to pin 10 of P1. Blower runs according to "Y1" and "Y/Y2" calls as noted above.
REVERSING VALVE	Thermostat calls for reversing valve "O"	The 24 VAC input signal is passed to pin 9 of P1. Blower runs according to "Y1" and "Y/Y2" calls as noted above.

C.1 Troubleshooting

WARNING

Electrical shock hazard. Only a trained, experienced service technician should perform troubleshooting procedure. Failure to do so could result in death or serious injury.

C.2 Preliminary Steps:

Consult Beckett or Riello instruction manuals provided with oil burner for specific information regarding oil burner primary control sequence of operation, diagnostics and troubleshooting.

Check diagnostic light for indications of burner condition.

NOTICE

When simulating call for heat at oil primary control, disconnect at least one thermostat lead wire from T - T terminals to prevent damage to thermostat. Neglecting this procedure may burn out heat anticipator of standard 24 vac thermostat, or cause harm to components within micro-electronic thermostat.

Before checking oil primary control, perform these preliminary checks, repair or replace controls as necessary:

- Check power supply, fuse box or breaker, any service switches, all wiring connections, and burner motor reset button (if equipped).
- Check limit switches to ensure switch contacts are closed.
- Check electrode gap and position.
- Check contacts between oil primary control and electrodes.
- Check oil supply (tank gauge).
- Check oil nozzle, oil filter, and oil valves.
- Check piping or tubing to oil tank.
- Check oil pump pressure.

C.3 Check Oil Primary Control

If the trouble does not appear to be in the burner or ignition hardware, check the oil primary control per manufacturer's instructions included with oil burner.

⚠ WARNING

Electrical shock hazard. Only a trained, experienced service technician should perform troubleshooting procedure. Failure to do so could result in death or serious injury.

Table C-3 - System and General Troubleshooting

Problem	Possible Cause	Remedy
Furnace will not start.	Thermostat not calling for heat	Check thermostat and adjust. Check thermostat for accuracy; if mercury switch type, it might be off level.
	No power to furnace	Check furnace switch, main electrical panel furnace fuse or circuit breaker. Look for any other hand operated switch, such as old poorly located furnace switch, which was not removed during furnace replacement.
	Thermostat faulty	Remove thermostat wires from oil primary control terminals T-T. Place a jumper across T-T. If furnace starts, replace thermostat, thermostat sub-base (if equipped), or both.
	Oil primary control faulty	Check reset button on oil primary control. Remove thermostat wires from oil primary control terminals T - T. Check for 24V across T -T. If no voltage is present, check for 115V to oil primary control. If 115V is present, refer to oil primary control documentation provided with oil burner.
	Photo Cell wiring shorted or room light leaking into photo cell compartment	Check photo cell (cad cell) wiring for short circuits. Check for room light leaking into cad cell compartment. Repair light leak if necessary.
	Open safety switch	Check for open limit or auxiliary limit. Check internal wiring connections; loose connectors, etc.
Furnace will not start without first pushing oil primary control reset button. (Happens on frequent basis)	No fuel oil	Check fuel oil supply. Check all hand operated fuel oil valves are in open position. Fill oil storage tank if necessary.
	Clogged nozzle	Replace nozzle with high quality replacement. Use rating plate or Tables in Appendix A as a guide.
	Clogged oil filter	Replace oil tank filter or in-line filter if used.
	Low oil pump pressure	Connect pressure gauge to oil pump. Adjust pump pressure, or replace oil pump if necessary. Verify erratic pressure readings are not caused by defective fuel oil line.
	Air getting into fuel oil lines, or fuel oil line dirty, clogged, or in some manner defective	Check fuel oil lines. Replace any compression fittings found with high quality flared fittings. Check for signs of oil leaks. Any oil leak is potential source of air or contaminants.
	Defective burner motor	Check burner motor. If burner motor is cutting out on over-load, determine why. Replace if necessary.

APPENDIX C - SEQUENCE OF OPERATION AND TROUBLESHOOTING

Table C-3: System and General Troubleshooting continued

Problem	Possible Cause	Remedy
Furnace starts, but cuts out requiring manually resetting oil protector reset button.	Photo Cell (Cad Cell) defective.	If cad cell is dirty, clean it. Determine why cad cell is getting dirty. If cad cell is poorly aimed, realign it. NOTE: Photocell should have resistance of 100 K Ω in absence of light; maximum of 1500 Ω in presence of light. Verify room light is not leaking into the cad cell compartment. (See diagnostic light section).
Furnace starts, but cuts out requiring manually resetting oil protector reset button.	No fuel oil.	Check fuel oil supply. Check that all hand operated fuel oil valves are in the open position. Fill oil storage tank if necessary.
	Clogged nozzle.	Replace nozzle with high quality replacement. Use rating plate or Tables in Appendix A as a guide.
	Clogged oil filter.	Replace oil tank filter or in-line filter if used.
	Low oil pump pressure.	Connect pressure gauge to oil pump. Adjust pump pressure, or replace oil pump if necessary. Verify erratic pressure readings are not caused by defective fuel oil line.
	Air getting into fuel oil lines, or fuel oil line dirty, clogged, or in some manner defective.	Check fuel oil lines. Replace any compression fittings found with high quality flared fittings. Check for any signs of oil leaks. Any oil leak is a potential source of air or contaminants.
	Defective burner motor.	Check burner motor. If burner motor is cutting out on over-load, determine why. Replace if necessary.
	Water or contaminants in oil.	Drain fuel oil storage tank; replace fuel oil. (Consult with fuel oil supplier).
	Frozen oil line.	Gently warm oil line. Insulate oil line. (Outdoor piping size may require increased diameter).
Oil burner sputtering at nozzle	Electrodes out of adjustment or defective.	Check electrode settings. Check electrodes for dirt build-up or cracks in porcelain.
	Poor igniter connections or defective igniter.	Check contacts between the igniter and electrodes. If OK, replace the igniter
	Fuel oil filter clogged.	Replace fuel oil storage tank filter and / or fuel oil in-line filter.
	Defective oil pump.	Check burner motor and / or fuel oil pump coupling. Check oil pump pressure. Replace fuel oil pump if necessary.
	Fuel oil line partially clogged or contains air.	Bleed air from oil line. If problem persists, replace oil line.
Excessive fuel oil consumption.	System temperature rise too high.	System temperature rise should not exceed 75°F. Check for clogged air filters. Check blower fan for excess dirt build-up or debris. Speed up blower fan if necessary.
	Poor "fan off" delay timing selection, (fan stops too soon).	Check "fan off" delay timing setting. Use duct thermometer in supply air plenum take-off or first few inches of supply air trunk duct. Fan should shut off at 90° - 100°F. Manipulate dip switch settings to come as close as possible to this "fan off" temperature.
	Fuel oil leak.	Check fuel oil line for leaks. Repair or replace if necessary.
	Stack temperature too high.	Check stack temperature. Stack temperatures will normally range from 400° to 500°F. Check draft regulator. Draft should be set to -0.02 in. w.c.
	Thermostat improperly adjusted or in poor location.	Check thermostat heat anticipator setting against measured amperage draw. Increase heat anticipator setting if necessary. If thermostat is being influenced by drafts, sunlight, duct work, etc., relocate to suitable location.

APPENDIX C - SEQUENCE OF OPERATION AND TROUBLESHOOTING

Table C-3: System and General Troubleshooting continued

Problem	Possible Cause	Remedy
Too much smoke.	Insufficient combustion air adjustment at oil burner, or improper draft pressure.	Adjust oil burner combustion air band and draft regulator to gain highest practical CO ₂ or lowest practical O ₂ content in flue gases. See Burner Set Up.
	Heat exchanger partially clogged.	Check for soot build-up in heat exchanger flue passages, especially in outer radiator.
Soot building up on blast tube (end coning).	Poor alignment between oil burner blast tube and fire pot.	Check alignment. Blast tube should be centered with fire pot burner opening. Oil burner head should be ¼ inch back from inside surface of fire pot.
	Flame impingement caused by incorrect nozzle angle.	Check nozzle size and angle. (See Appendix A). Check distance from head to inside surface of fire pot.
	Defective fire-pot	Check fire-pot. Repair or replace.
Furnace will not warm home to desired temperature.	Airflow blocked or dirty air filter.	Clean or replace air filter.
	Thermostat adjustments or location.	Check thermostat heat anticipator setting against measured amperage draw. Increase heat anticipator setting if necessary. If thermostat is being influenced by drafts, sunlight, duct work, etc., relocate to suitable location.
	Insufficient airflow.	Check all dampers. Open closed dampers including registers in unused rooms. Check system temperature rise. If temperature rise is too high, speed up blower fan.
	Defective high limit control.	Test high limit function of all limit switches. Use duct thermometer to verify accuracy of limit control. Check for obstructions to airflow around limit switch bimetal elements. Replace control if necessary.
	Under-sized nozzle.	Check nozzle. If problem is not caused by air flow problems, use larger nozzle, if permitted by rating plate.
	Blower fan motor stopping intermittently on overload.	Check blower fan motor amperage draw. Check motor ventilation ports, clean if necessary. Replace motor if necessary.
	Burner motor stopping intermittently on overload.	Check burner motor. Replace if necessary.
Home does not heat evenly	Improper distribution of heat.	This is not likely to be a furnace problem. Balance duct system.
Supply air temperature too hot.	Airflow blocked or dirty air filter.	Clean or replace air filter.
	Insufficient airflow.	Check all dampers. Open closed dampers including registers in unused rooms. Check system temperature rise. If temperature rise is too high, speed up blower fan.
Supply air temperature too cool.	Excess airflow.	Check system temperature rise. Slow down blower fan if necessary.
	Excessive duct losses.	Check supply air ductwork. Seal leaky joints and seams. Insulate ductwork if necessary.
Supply air temperature too cool during first moments of furnace cycle.	Fan control "fan on" setting too low.	Increase "fan on" dipswitch settings on EFT if control has this option. Register air deflectors may help.
	Excessive duct losses.	Check supply air ductwork. Seal leaky joints and seams. Insulate ductwork if necessary.

APPENDIX D - HOMEOWNER'S REFERENCE TABLE

Model No.	
Serial No.	
Date Installed	
Contractor	
Contact	
Address	
Postal Code	
Telephone No.	
After Hours No.	

Fuel Supplier

Fuel Oil Supplier	
Contact	
Telephone No.	
After Hours No.	

PARTS LISTING

Parts Listing: Chimney Vent Models LRF/LRFV

Ref. No.	Description	Part No.
1	Left Side Panel	109009625AD
2	Right Side Panel	109009624AD
3	Base Panel Assembly	550003225
4	Rear Panel	109009626AD
5	Blower Door	109009809AD
6	Front Panel	109009786AD
7	Logo Bezel	28479
	Logo Label Olsen	28563
	Logo Label Airco	28564
8	Handle (2 per unit)	28673
9	Top Panel	109008787AD
10	Blower Division Panel	3002357
11	Inner Front Panel	109009627
12	Cleanout Cover (Includes one item 19)	550003223
13	Left Side Baffle	109009710
14	Right Side Baffle	109009709
15	Vertical Baffle (2 per unit)	109009711
16	Insulation Retainer (4 per unit)	26047
17	Heat Exchanger (Includes 18,19,20, 25)	550003224
18	Turbulators (18 per unit)	109009176
19	Cleanout Cover Gasket (2 per unit)	240010371
20	Burner Plate Gasket	240010370
21	Front Flue Pipe Assembly	3002314
22	Rear Flue Pipe Assembly	3002317
23	Flue Pipe Insulator Pipe	29713
24	Flue Pipe Flange	109009797
25	Flue Pipe Gasket (3 per unit)	240011382
26	Observation Port Sight Glass	240008235
27	Sight Glass Washer	109009449
28	Plug for Draft Measurement Port M10 x 16 Flange Bolt	240010827
29	Limit Disc 60T11 BOF 260°F	30153
30	Limit Disc Retainer	109009401
31	Control Box	30010
32	Control Box Cover (Direct Drive PSC Models)	109009791
	Control Box Cover (Direct Drive ECM and Belt Drive Models)	29654
33	Fan Timer Control 1158-120 UTEC (PSC and Belt Drive Models)	29388
	Fan Timer Control 1168-1 UTEC (ECM Models)	240007048
34	Transformer 120-24 VAC 40VA	240005330
35	Low Speed Fan Switch (Direct Drive PSC Models Only)	20693
36	Blower Assembly - Direct Drive PSC Motor (includes 39)	550003217
	Blower Housing and Wheel 100-10T Direct Drive	240010315
	Blower Motor 1/2 HP 4 Speed	102000131
	Motor Mounting Band TR6884B	17811
	Motor Mounting Arms	26251
	Motor Run Capacitor 10 mfd @ 370 VAC	27743
	Capacitor Strap	27761
	Blower Base (2 per unit)	109005826
Grommet, Blower Feet (4 per unit)	26415	

PARTS LISTING

Parts Listing: Chimney Vent Models LRF/LRFV - CONTINUED

Ref. No.	Description	Part No.
37	Blower Assembly - Direct Drive ECM Motor (includes 39)	550003218
	Blower Housing and Wheel 100-10T Direct Drive	240010315
	Blower Motor 1/2 HP ECM Programmed	102000186
	Motor Mounting Band TR6884B	17811
	Motor Mounting Arms	26251
	Blower Base (2 per unit)	109005826
	Grommet, Blower Feet (4 per unit)	26415
38	Blower Assembly - Belt Drive Motor (includes 39)	550003219
	Blower Housing and Wheel 100-10T Belt Drive	240011512
	Blower Motor 1/2 HP Single Speed 1725 RPM	102000154
	Pulley Motor 3-1/4 x 1/2 MVL	2240001
	Pulley Blower 6 x 3/4	2240006
	Belt 4L370	2240016
	Motor Support Bracket	109008679
	Tensioner Support Bracket	109008680
	Blower Base (2 per unit)	109005826
Grommet, Blower Feet (4 per unit)	26415	
39	Auxiliary Limit Disc 60T11 BOF 130°F	30388
40	Oil Burner Assembly Beckett AFG70MPSS +	550003430
	Oil Burner Assembly Riello 40F3 +	550003431
	Oil Burner Assembly Carlin EZ-LF +	550003432
41	Filter Side Rail (2 per unit)	27370
42	Filter Blower Division Rail	27369
*	Air Filter 20 x 20 x 1 Permanent	2180032
*	Wire Harness Control Board Power	29751
*	Wire Harness Direct Drive PSC Blower	240011383
*	Wire Harness Control Board to Burner and Limits	240011384
*	Wire Harness Direct Drive ECM Blower Control Intermediate	240011385
*	Wire Harness Direct Drive ECM Blower Control Ends (2 per unit)	240011386
*	Wire Harness Direct Drive ECM Blower Power	240011387
*	Wire Harness Belt Drive Blower	240011389
*	Blocked Vent Safety Switch Kit Complete	30690
*	Blocked Vent Safety Switch - Replacement Switch Only	30660
*	Flue Pipe for Blocked Vent Safety Switch	30655
*	Draft Regulator	27494
*	0.60-60°W Oil Nozzle	240007739
*	0.65-60°W Oil Nozzle	240006431
*	0.50-90°B Oil Nozzle	240010815
*	0.65-80°B Oil Nozzle	1320011
*	0.75-80°B Oil Nozzle	1320008
*	0.65-70°B Oil Nozzle	14619022
* = Not Shown		
+ = Burner kit includes nozzles and required hardware for all firing rates and includes wiring to connect to furnace.		

PARTS LISTING

Parts Listing: Direct Vent Models LRF/LRFV

Ref. No.	Description	Part No.
All parts are same as listed for chimney vent models except as listed below.		
12	Cleanout Cover w/ Pressure Tap for Direct Vent (Includes one item 19)	550003409
40	Oil Burner Assembly, Beckett NX56LQ +	550003435
	Oil Burner Assembly, Riello 40BF3 (0.55/0.65 USGPH Firing Rates)+	550003433
	Oil Burner Assembly, Riello 40BF5 (0.75/0.85 USGPH Firing Rates)+	550003434
*	Pressure Switch for use with Riello Burners 0.42" WC (Blocked Vent Safety Switch)	240011861
*	Pressure Switch for use with Beckett Burners 0.65" WC (Blocked Vent Safety Switch)	240011862
*	5" x 4" Appliance Adapter - Connects Furnace to Vent Pipe	240011898
*	Combustion Air Intake Collar 4" for Beckett Burner	109005950
*	Combustion Air Intake Collar 3" for Riello Burner	109006030
*	Combustion Air Intake Elbow 3" for Riello Burner	240011899
*	Combustion Air Intake Increaser 3" x 4" for Riello Burner	240011310
*	4" x 10' Vent Kit (Includes Vent Terminal Connector)	240006909
*	4" x 15' Vent Kit (Includes Vent Terminal Connector)	240006910
*	4" x 20' Vent Kit (Includes Vent Terminal Connector)	240006911
*	4" Vent Terminal Connector - Connects Vent Pipe to Vent Terminal	240006914
*	Standard Vent Terminal	28972
*	Riser Vent Terminal	29231
*	Wire Harness Control Board to Burner and Limits and Pressure Switch	240011894
* = Not Shown		
+ = Burner kit includes nozzles and required hardware for applicable firing rates and includes wiring to connect to furnace. Burner kit also includes applicable pressure switch and tubing connections.		

Model LRF/LRFV Diagram

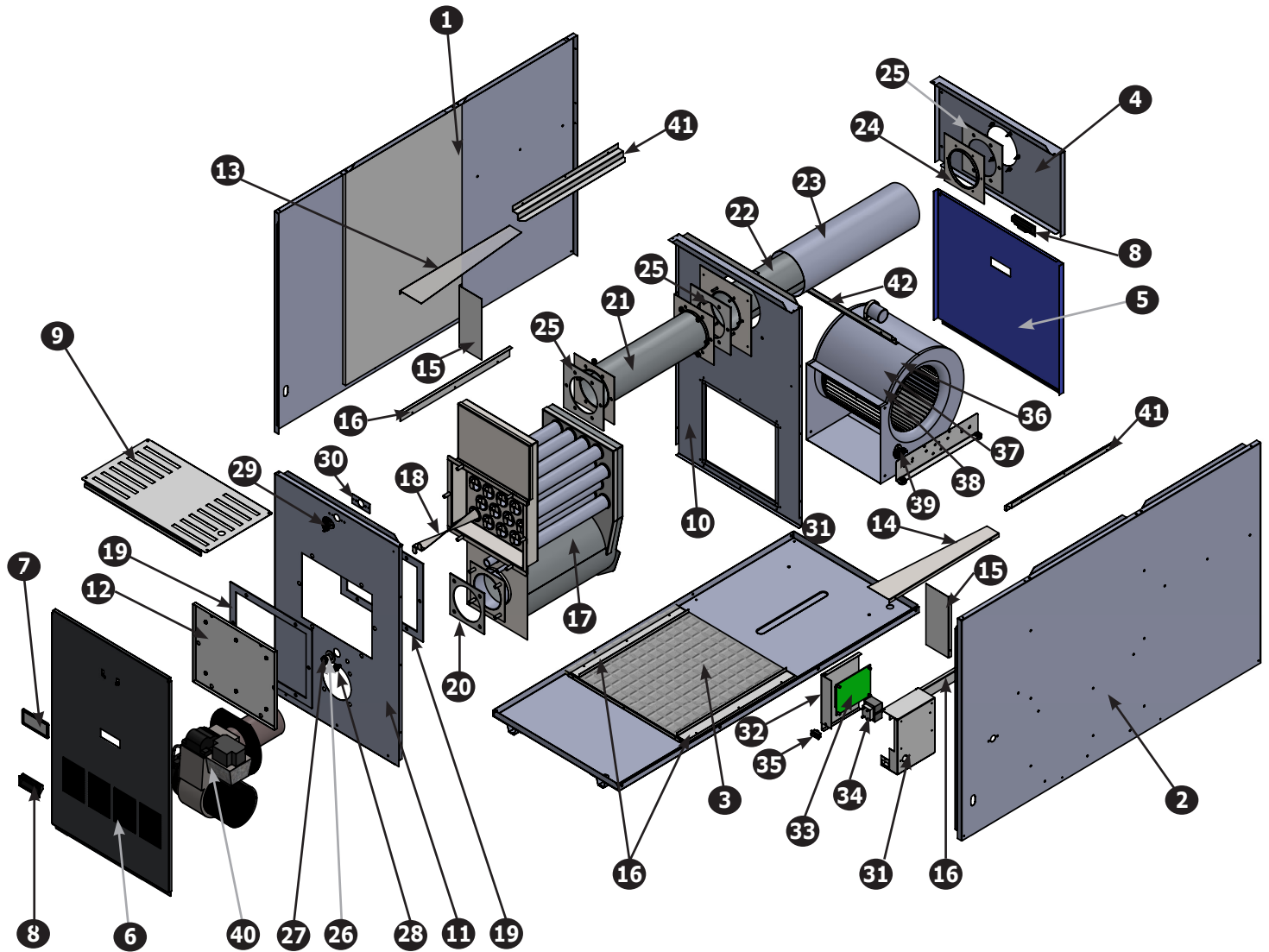



2201 Dwyer Avenue, Utica, NY 13501
Tel. 800 253 7900
www.ecrinternational.com

All specifications subject to change without notice.
©2018 ECR International, Inc.